

Auxiliary switch unit, suitable on the spring return actuators NF..A., SF..A. and LF..

- two switches (SPDT)
- adjustable switching points
- including adapter

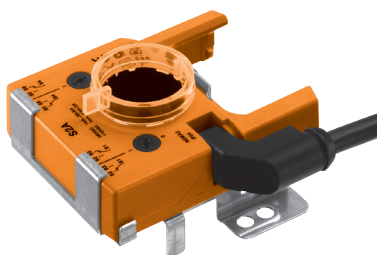

### Technical data

<b>Functional data</b>	Number of switches	2 x SPDT
	Switching capacity	1 mA ... 3 (0.5) A, AC 250 V <input type="checkbox"/>
	Switching point	Adjustable over the full range of rotation of the actuator (0 ... 1). Can be preset by means of the scale.
	Connection	Cable 1 m, 6 x 0.75 mm <sup>2</sup>
<b>Safety</b>	Protection class	II Totally insulated <input type="checkbox"/>
	Degree of protection	IP54
	Low-voltage directive	CE according to 2006/95/EC
	Certification	Certified to IEC/EN 60730-1 and IEC/EN 60730-2-14
	Mode of operation	Type 1.B
	Control pollution degree	3
	Ambient temperature	-30 ... +50°C
	Non-operating temperature	-40 ... +80°C
<b>Dimensions / weight</b>	Ambient humidity	95% r.h., non-condensating
	Maintenance	Maintenance-free
	Dimensions	See «Dimensions» on page 2
	Weight	Approx. 140 g

### Safety notes



- The device is not allowed to be used outside the specified field of application, especially in aircraft or in any other airborne means of transport.
- It may only be installed by suitably trained personnel. Any legal regulations or regulations issued by authorities must be observed during assembly.
- The device may only be opened at the manufacturer's site. It does not contain any parts that can be replaced or repaired by the user.
- The cable must not be removed from the device.
- The device contains electrical and electronic components and is not allowed to be disposed of as household refuse. All locally valid regulations and requirements must be observed.

### Product features

<b>Application</b>	The auxiliary switch is used for signaling the position or to exercise the switching functions in any chosen angle position.
<b>Mode of operation</b>	A carrier plate takes a positive grip on the spring-return actuator and transfers the position direct to the microswitch trip cam. The switching points can be selected at random for the required rotation angle range using an adjustment dial. The current switch setting can be read off at any time.
<b>Installation</b>	The auxiliary switch unit is connected directly by means of adaption with the hollow shaft (LF., NF..A., SF..A.) of the actuator. Once it is mounted, the unit is screwed to the actuator.

Electrical installation

Wiring diagram

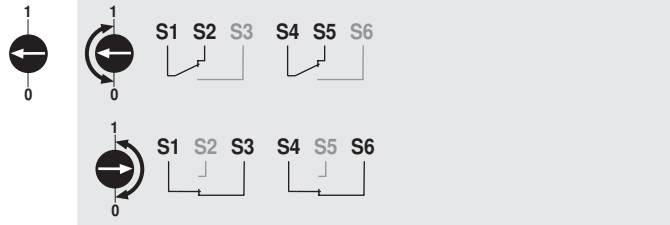
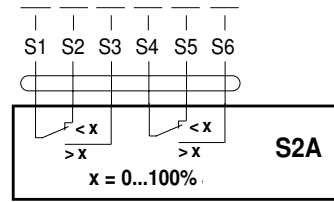

Dimensions [mm]

Dimensional drawings with NF..A.. / SF..A..

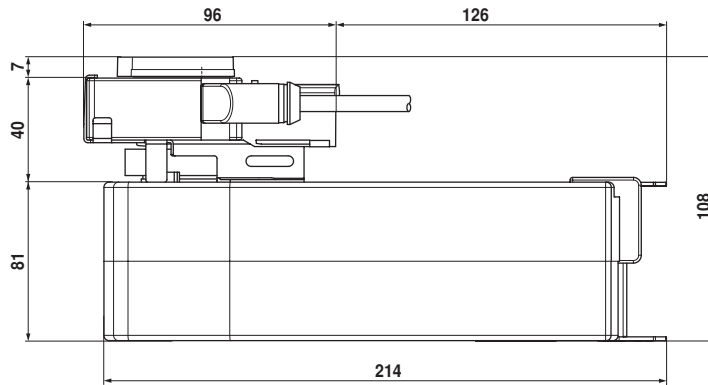
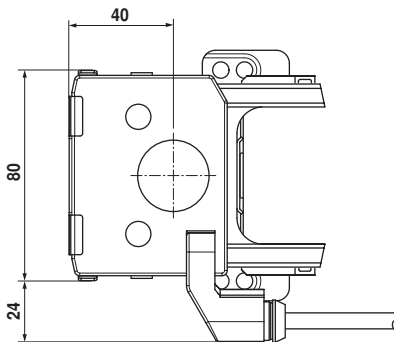

with LF..

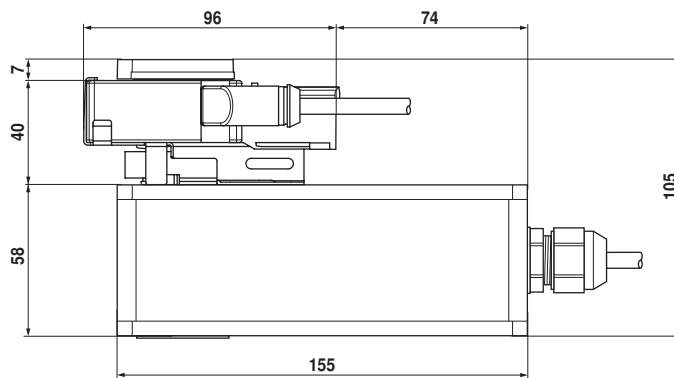

## S2A-F

S1 S2 S3 S4 S5 S6

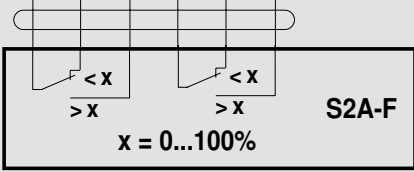

## P..A-F

S1 S2 S3

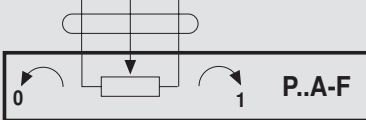

## NF..A.. / SF..A..

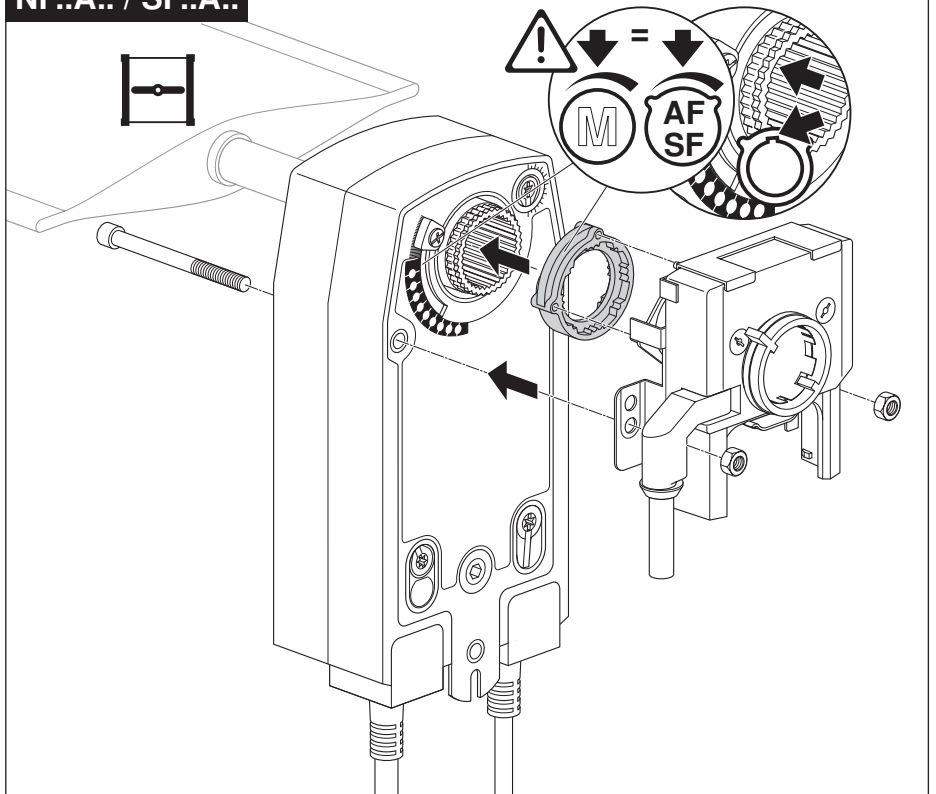

## LF..

