



## WFD Series Waterflow Detector

*The System Sensor WFD series is compatible with schedule 10 through 40 steel pipe, sizes 2" through 8", and can be mounted in a vertical or horizontal position.*



### Features

---

- Two-inch mounting hole provided in new WFD30-2 models
- UL-listed models are NEMA 4 rated
- Sealed retard mechanism immune to dust and other contaminants
- Visual switch activation
- Field-replaceable retard mechanism and SPDT switches
- Rugged, dual SPDT switches enclosed in a durable terminal block
- Accommodates up to 12 AWG wire
- Designed for both indoor and outdoor use
- 100 percent synchronization activates both alarm panel and local bell
- Tamper-resistant cover screws

**Robust Construction.** The WFD series consists of a rugged, NEMA 4-rated enclosure. Designed for both indoor and outdoor use, the WFD series operates across a wide temperature range, from 32°F to 120°F.

**Reliable Performance.** UL-listed models are equipped with tamper-resistant cover screws to prevent unauthorized entry. Inside, two sets of SPDT (Form C) synchronized switches are enclosed in a durable terminal block to assure reliable performance.

**False Alarm Immunity.** The WFD series incorporates a mechanical retard feature, which minimizes the risk of false alarm due to pressure surges or air trapped in the sprinkler system. In addition, the mechanical retard's unique sealed design is immune to dust and other contaminants.

**Simplified Operation.** The WFD series is designed to simplify installation. Two conduit openings permit easy attachment to the local alarm system. The retard mechanism and dual SPDT switches are field-replaceable.

### Agency Listings

---



# Waterflow Detector Specifications

## Engineering Specifications

Vane-type waterflow detectors shall be installed on system piping as designated on the drawing and/or as specified herein. Detectors shall mount on any clear pipe span of the appropriate nominal size, either a vertical upflow or horizontal run, at least 6" from any fittings that may change water direction, flow rate, or pipe diameter or no closer than 24" from a valve or drain. Detectors shall have a sensitivity in the range of 4 to 10 gallons per minute and a static pressure rating of 450 psi\* for 2" – 8" pipes. The detector shall respond to waterflow in the specified direction after a preset time delay that is field adjustable. The delay mechanism shall be a sealed mechanical pneumatic unit with visual indication of actuation. The actuation mechanism shall include a polyethylene vane inserted through a hole in the pipe and connected by a mechanical linkage to the delay mechanism. Outputs shall consist of dual SPDT switches (Form C contacts). Two conduit entrances for standard fittings of commonly used electrical conduit shall be provided on the detectors. A grounding provision is provided. Unless noted, enclosures shall be NEMA 4 listed by Underwriters Laboratories Inc. All detectors shall be listed by Underwriters Laboratories Inc. for indoor or outdoor use.

## Standard Specifications

<b>Static Pressure Rating</b>	450 PSI*	<b>Operating Temperature Range</b>	32°F to 120°F (0°C to 49°C)
<b>Maximum Surge</b>	18 Feet Per Second (FPS)	<b>Enclosure Rating*</b>	NEMA 4 – suitable for indoor/outdoor use
<b>Triggering Threshold Bandwidth (Flow Rate)</b>	4–10 GPM	<b>Cover Tamper Switch</b>	Standard with ULC models, optional for UL models, part no. 546-7000
<b>Conduit Entrances</b>	Two openings for ½" conduit. One open, one knock-out type	<b>Service Use</b>	Automatic Sprinkler: NFPA-13 One or Two Family Dwelling: NFPA 13D Residential Occupancies up to 4 Stories: NFPA 13R National Fire Alarm Code: NFPA-72
<b>Contact Ratings</b>	Two sets of SPDT (Form C) 10.0 A, ½ HP @ 125/250 VAC 2.5 A @ 6/12/24 VDC	<b>U.S. Patent Numbers</b>	5,213,205
<b>Compatible Pipe</b>	Steel water pipe, schedule 10 through 40	<b>Warranty</b>	3 Years

## WFD Field Wiring Diagram

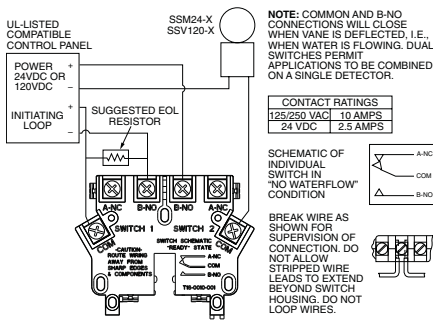

## Delay Adjustment Dial

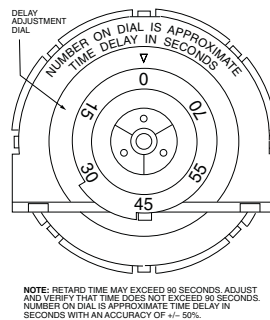

## Overall Dimensions, Installed

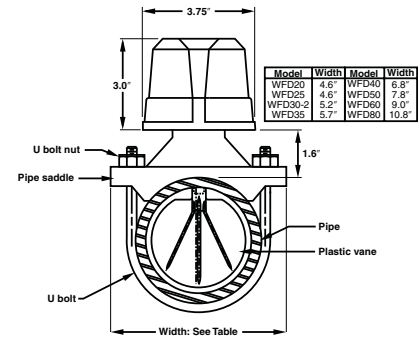

## Ordering Information

UL Model	ULC Model	Pipe Size	Hole Size	Shipping Weight
WFD20	WFD20A	2"	1¼"	4.2 lbs.
WFD25	WFD25A	2½"	1¼"	4.3 lbs.
WFD30-2	WFD30-2A	3"	2"	4.5 lbs.
WFD35	WFD35A	3½"	1¼"	4.7 lbs.
WFD40	WFD40A	4"	2"	5.2 lbs.
WFD50	WFD50A	5"	2"	6.3 lbs.
WFD60*	WFD60A	6"	2"	6.8 lbs.
WFD80*	WFD80A	8"	2"	7.5 lbs.

## Accessories

A3008-00	Retard mechanism
A77-01-02	Terminal block
546-7000	Tamper-proof switch kit
WFDW	Tamper-proof wrench for cover
WFDN4	Gasket kit

\*Maximum pressure rating 400 psi as approved by Factory Mutual.



3825 Ohio Avenue • St. Charles, IL 60174  
Phone: 800-SENSOR2 • Fax: 630-377-6495

©2009 System Sensor.  
Product specifications subject to change without notice. Visit systemsensor.com for current product information, including the latest version of this data sheet.  
A05-0180-013 • 1/09 • #1922