

## Q-Series

### Outdoor Air and Critical Environment Relative Humidity and Relative Humidity & Temperature Sensors



#### Description

The Q-Series Outdoor Air Relative Humidity and Relative Humidity & Temperature Sensors monitor and transmit changes in humidity and temperature to the building control systems.

#### Features

- Operating voltage 24 Vac/13.5 to 35 Vdc
- Signal output 0 to 10 Vdc/4 to 20 mA for relative humidity and temperature
- Very high measuring accuracy across the entire measuring range
- Capacitive humidity measurement
- Precise, stable humidity sensing
- Available in 2% and 2%, certified models
- Recalibration service (QFA4160)

#### Application

The Q-Series Outdoor Air rh and rh/T Sensors are for use in HVAC applications where high accuracy and short response times for measuring relative humidity are required. The measuring range covers the entire humidity range of 0 to 100%. Some application examples:

- Storage and production facilities in the paper, textile, pharmaceutical, food, chemical and electronics industry, etc.
- Laboratories
- Hospitals
- Computer and EDP centers
- Greenhouses
- With the AQF3100 accessory for outdoor use

**Product Numbers**

**Table 1.**

Product Number	Accuracy	Temperature Measuring Range	Temperature Signal Output	Humidity Measuring Range	Humidity Signal Output	Operating Voltage
QFA3100	2%	None	None	0 to 100%	Active, 0 to 10 Vdc	24 Vac or 13.5 to 35 Vdc
QFA3101					Active, 4 to 20 mA	13.5 to 35 Vdc
QFA3160		32°F to 122°F (0°C to 50°C), -31°F to 95°F (-35°C to 35°C), <b>or</b> -40°F to 158°F (-40°C to 70°C)	Active, 0 to 10 Vdc		Active, 0 to 10 Vdc	24 Vac or 13.5 to 35 Vdc
QFA3171			Active, 4 to 20 mA		Active, 4 to 20 mA	13.5 to 35 Vdc
QFA4160	2%, certified	None	Active, 0 to 10 Vdc		Active, 0 to 10 Vdc	24 Vac or 13.5 to 35 Vdc
QFA4171					Active, 4 to 20 mA	Active, 4 to 20 mA

**Accessories**



AQF3101	Sensor filter cap (replacement)
AQF3150	Replaceable, 2% sensor tip
AQF4150	Replaceable, certified sensor tip
AQF3100	Outdoor Mounting Kit (including sun shield)

**Outdoor Mounting Kit  
 AQF3100**

The Outdoor Mounting Kit consists of:

- One wall mounting bracket complete with sun shield
- Four Phillips-head screws, K35 x 12
- One grommet M 16 x 1.5 with O-ring and nut M 16 x 1.5 for closing off the sensor's cable entry hole if not required.

**Warning/Caution Notations**

<b>WARNING:</b>		Personal injury, or loss of life may occur if you do not perform a procedure as specified.
<b>CAUTION:</b>		Equipment damage may occur if you do not perform a procedure as specified.

---

### Ordering Information

The **AQF3100** outdoor mounting kit listed under *Accessories* must be ordered as a separate item.

The circular connector with its screwed plug is delivered uninstalled (QFA4160).

---

### Equipment Combinations

The Q-Series Outdoor Air Relative Humidity and Relative Humidity & Temperature Sensors can be used with all types of systems and devices that can acquire and handle the sensor's 0 to 10 Vdc or 4 to 20 mA output signal.

---

### Technical Design

#### Relative Humidity

The sensor acquires relative humidity via its capacitive sensing element; the capacitance varies as a function of the relative humidity of the ambient air. An electronic circuit converts the sensor's signal to a continuous 0 to 10 Vdc or 4 to 20 mA signal, which corresponds to a relative humidity of 0 to 100%.

---

#### Temperature

The sensor acquires the temperature via its sensing element; the electrical resistance varies according to the temperature of the ambient air.

This variation is converted to an active 0 to 10 Vdc or 4 to 20 mA output signal, corresponding to a temperature range of 32°F to 122°F, -31°F to 95°F, or -40°F to 158°F (0°C to 50°C, -35°C to 35°C, or -40°C to 70°C). The measuring range can be selected.

---

### Resistive Load Diagram

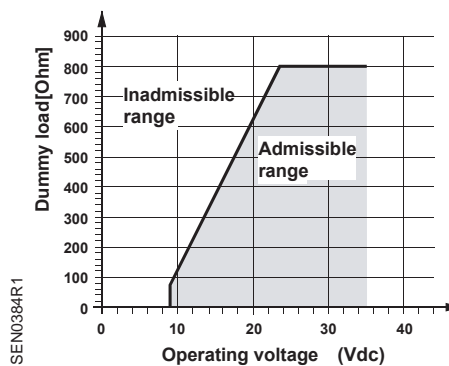

Figure 1. Output Signal, Terminal I1/I2.

---

### Mechanical Design

The room sensor consists of housing, printed circuit board, connection terminals and measuring rod. The housing consists of two parts: base and removable cover (screwed). The QFA4160 also has a circular connector.

The measuring circuit and the setting element are located inside the cover of the printed circuit board; the connection terminals are in the base. The housing and measuring rod are screwed together.

The sensing elements are located at the end of the measuring rod and are protected by a screw-on filter cap.

For the QFA31 Series, the M16 cable entry gland supplied with the sensor can be screwed into the bottom of the base. If the sensor is used outdoors, that opening must be closed off and the prepared hole on the opposite side of the base knocked out.

For the QFA41 Series, the cable entry is made via the circular connector, which consists of a coupling piece with M16 thread and a connector with a screwed plug. The coupling piece is secured to the housing and internally wired. The sensor is designed for wall mounting.

---

## Setting Element

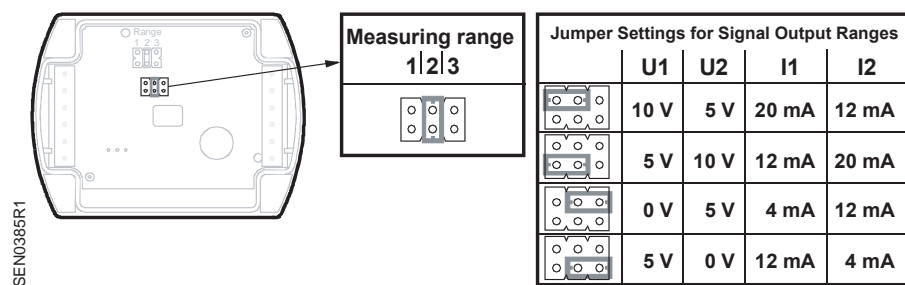

**Figure 2. Configuring the Jumpers.**

The setting element is located inside the cover. It consists of six pins and a jumper. They are used to select the required temperature measuring range and to activate the test function. The different jumper positions have the following meanings:

- **For the active (0 to 10V or 4 to 20 mA) temperature measuring range with the jumper in the:**  
 Left position (1) = -31°F to 95°F (-35°C to 35°C)  
 Mid position (2) = 32°F to 122°F (0°C to 50°C) (factory setting)  
 Right position (3) = -40°F to 158°F (-40°C to 70°C)
- **For the active test function:**  
 Jumper in the horizontal position: See Figure 2. Jumper Settings for Signal Output Ranges for the values available at the signal output.

## Behavior in the Event of a Fault

- If the temperature sensor is faulty, the voltage at signal output U2 (I2) is 0V (4 mA) after 60 seconds. The humidity signal at signal output U1 (I1) increases to 10V (20 mA).
- If the humidity sensor is faulty, the voltage at signal output U1 (I1) is 10V (20 mA) after 60 seconds. The temperature signal remains active

## Calibration Certificates (QFA41 Series only)

The sensor and its exchangeable AQF4150 measuring tip are numbered, registered and calibrated prior to delivery. The associated calibration certificates are supplied with the sensor.

## Engineering Notes

- Use a safety extra low-voltage (SELV) transformer with separate windings designed for 100% duty.
- Observe all local and national safety regulations when sizing and protecting the transformer.
- Take the sensor's power consumption into consideration when sizing the transformer.
- See the devices' Installation Instructions for the sensor's electrical connection.
- Observe the maximum permissible cable lengths.

## Cable Routing and Cable Selection

Electrical interference increases the longer the cables run parallel and the smaller the distance is between them. Use shielded cables if necessary. Twisted pairs of cables are required for the secondary supply lines and the signal lines.

---

## Mounting Notes

### Interior Mounting for QFA31 Series without AQF3100

- Mount on an inside wall (not on outside wall) of the room to be air-conditioned. Do not mount in recesses, shelves, behind curtains, above or close to heat sources; or on walls behind which a chimney is located.
- Do not expose the sensor to direct sunlight.
- Install the sensor in an occupied space approximately five feet (1.5 m) above the floor and at least 20 inches (50 cm) from the next wall.

#### CAUTION:



- Do not remove the seal between the housing and cover. The degree of protection IP 65 will be no longer ensured if the seal is removed.
- Avoid any impact while mounting. The sensing elements inside the measuring rod are sensitive to shock and impact.

---

#### Mounting Position

The sensor must be mounted with the measuring rod pointing downward for the QFA41 Series or the QFA31 Series (without the AQF3100 Outdoor Mounting Kit).

---

#### Mounting Instructions

Installation Instructions are printed on the sensor's packaging

---

### Outdoor Mounting for QFA31 Series with AQF3100

#### Mounting Location

Mount on an exterior wall, preferably on the north or northwest side of the building. If possible, mount in the middle of the wall, at least 8 feet (2.5 meters) above the ground. Do not mount above or below windows, above doors or ventilation shafts, or below balconies or eaves.

---

#### Mounting Position

The sensor and AQF3100 must be mounted in a vertical position (with the sun shield at the top).

**NOTE:** When using the AQF3100 outdoor mounting kit, the sensor's cable entry hole must be closed off with the grommet and the prepared M16 cable entry on the opposite side knocked out.

---

#### Mounting Instructions

Installation Instructions are printed on the sensor's packaging

---

## Commissioning Notes

- Check the wiring before switching on power.
- Select the required temperature measuring range on the sensor.

---

## Recalibration Service

Siemens Building Technologies, Inc. provides a recalibration service for used sensors. Recalibration should be performed at 12-month intervals under normal conditions (that is within the comfort range for humidity and temperature and at air contamination levels that are not above average).

---

#### Services Provided

The recalibration service includes the following:

- Delivery and invoicing of the new AQF4150 measuring tip, complete with calibration certificate.
  - Delivery of a calibration certificate for the (old) measuring tip returned to Siemens Building Technologies, Inc. enabling the customer to assess the time of usage of the measuring.
-

<b>Specifications</b>	Operating voltage	24 Vac $\pm$ 20% or 13.5 to 35 Vdc
	Frequency	50/60 Hz at 24 Vac
<b>Power Supply</b>	Power consumption	$\leq$ 1 VA
<b>Humidity element</b>	Operating range	0 to 100% rh
	Measurement range	0 to 95% rh
	Accuracy at room temperature (73°F [20°C])	$\pm$ 2% rh, 0 to 95% rh
	Time constant	Approx. 20 s in moving air
	Output signal, linear (terminal U1)	0 to 10 Vdc = 0 to 100% rh Max. $\pm$ 1 mA
	Operating temperature	-40°F to 158°F (-40°C to 70°C)
	Temperature effect	< 0.1% per degree Celsius
	Sensing element	Capacitive humidity sensing element
	Output signal (rh only units)	4 to 20 mA or 0 to 10 Vdc, 0 to 100% linear, proportional
	Output signal (rh/T units)	4 to 20 mA or 0 to 10 Vdc, 0 to 100% linear, proportional
Polarity protection	Yes	
<b>Temperature element (for combination rh/T units only)</b>	Operating temperature, jumper selectable	32°F to 122°F (0°C to 50°C) or -31°F to 95°F (-35°C to 35°C), -40°F to 158°F (-40°C to 70°C)
	Time constant @ 32°F to 122°F (0°C to 50°C) and 10 to 80% rh	Approximately 20 s in moving air
	Accuracy	
	@ 32°F to 122°F (0°C to 50°C)	$\pm$ 1.8°F ( $\pm$ 1°C)
	@ -31°F to 95°F (-35°C to 35°C)	$\pm$ 1.4°F ( $\pm$ 0.8°C)
	@ 32°F to 158°F (0°C to 70°C)	$\pm$ 1.8°F ( $\pm$ 1°C)
Output signal	4 to 20 mA or 0 to 10 Vdc, 0 to 100% linear, proportional	
Calibration adjustments	None	
<b>General</b>	Installation	18 AWG cable length shared in conduit with other sensor wiring. 750 ft (229 m) maximum
	Connections	Screw terminals
	Dimensions	
	Outdoor air probe	6" OD $\times$ 3.3" L (15 mm $\times$ 84 mm)
	Outdoor air housing	3.1" L $\times$ 2.3" W $\times$ 1.5" D (80 mm $\times$ 60 mm $\times$ 40 mm)
	Shield (mounted)	3.43" H $\times$ 3.5" W $\times$ 4.1" D (87 mm $\times$ 89 mm $\times$ 104 mm)
	Voltage requirement	13.5 to 35 Vdc
Material type	Polycarbonate plastic	
Protection class rating	IP 65 (NEMA 4)	
<b>Agency certification</b>	<b>CE</b> Conforms to UL Listing cUL Listing	EMC Directive 89/336/EEC UL873 XAPX Canadian Standard C22.2 No. 24-93
	<b>Conforms to Australian EMC Framework Radio Interference Emission Standard</b>	Radio Communication Act 1992 AS/NZS 3548

### Wiring Terminals

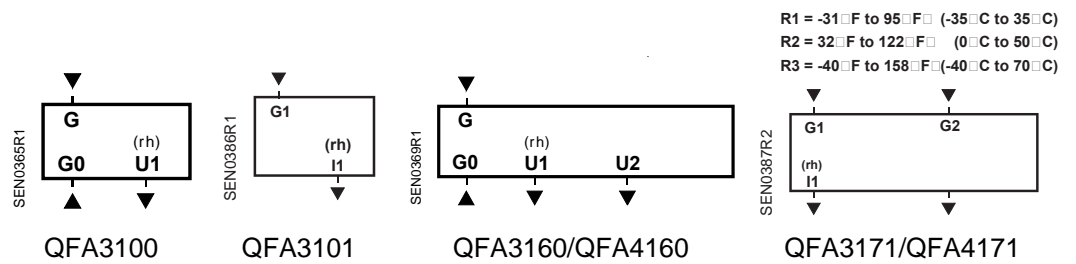

Figure 3. Wiring Terminals.

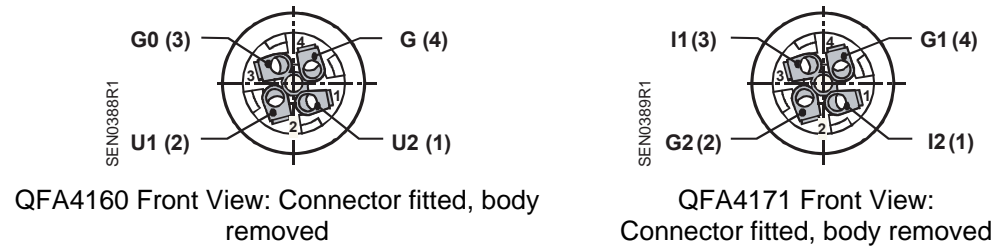

Figure 4. Connectors.

### Dimensions

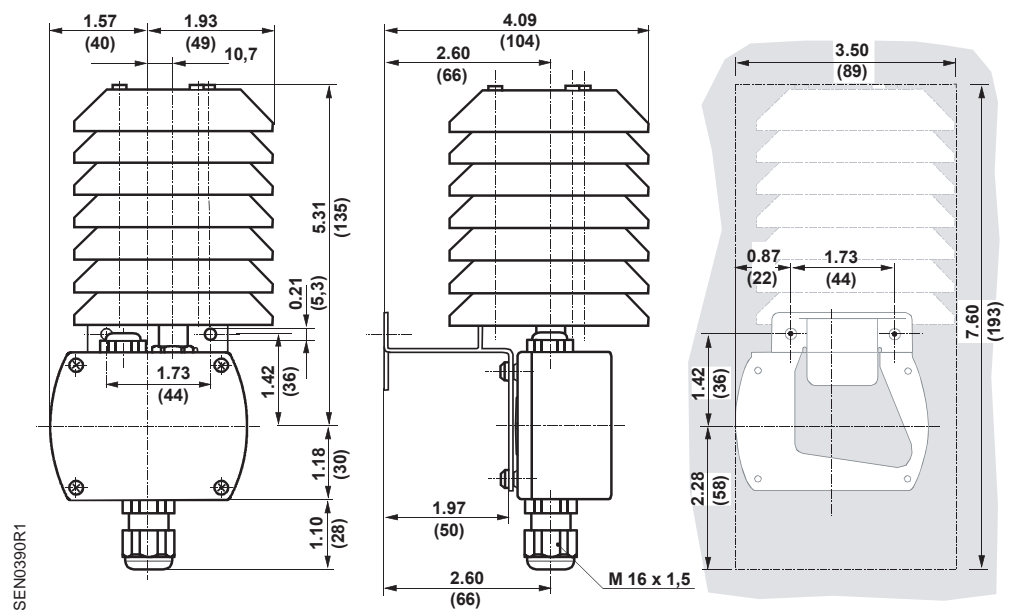
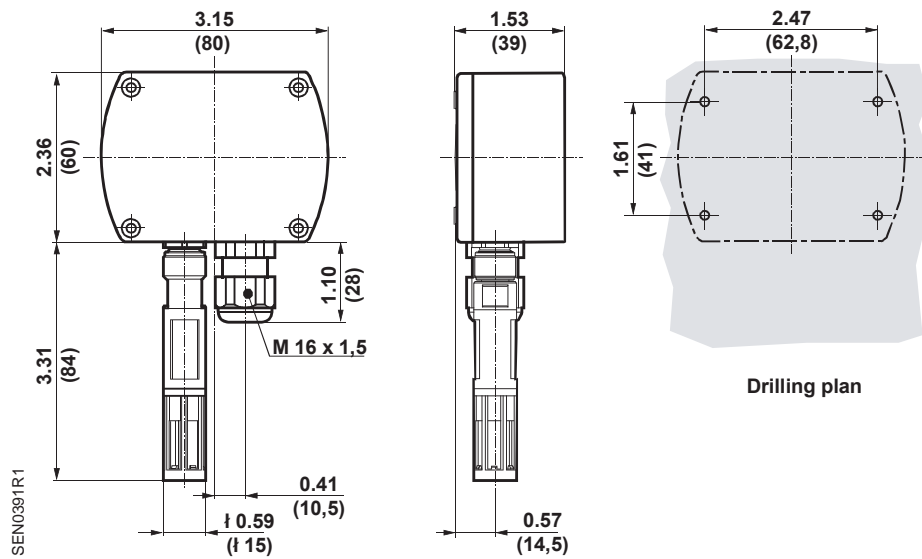
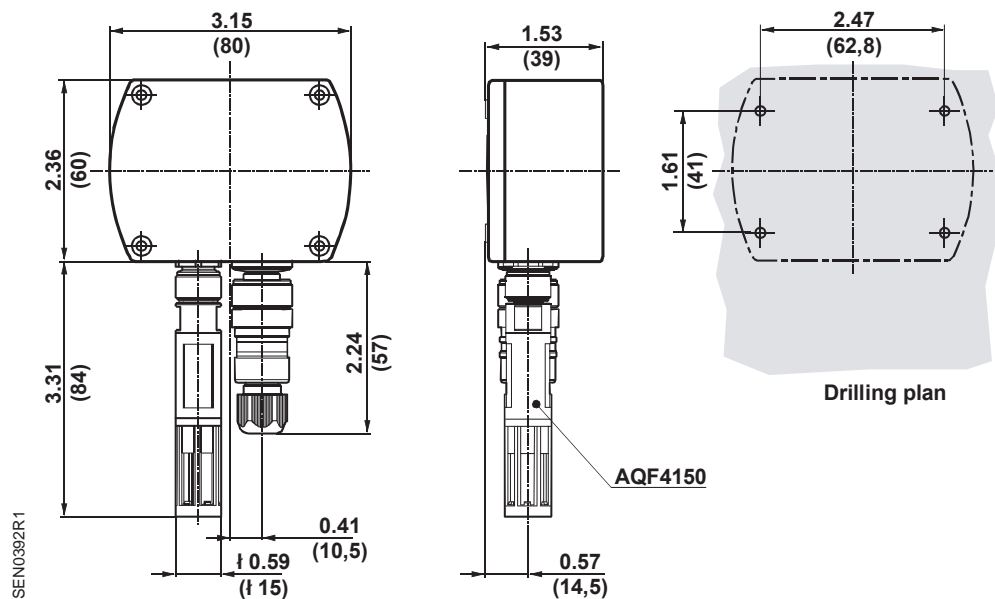

Figure 5. QFA31 Series Sensors with AQF3100 Dimensions in Inches (Millimeters).

**Dimensions,  
 Continued**



**Figure 6. QFA31 Series Dimensions in Inches (Millimeters).**



**Figure 7. QFA41 Series Sensors Dimensions in Inches (Millimeters).**

Information in this publication is based on current specifications. The company reserves the right to make changes in specifications and models as design improvements are introduced. Other product or company names mentioned herein may be the trademarks of their respective owners.  
 © 2007 Siemens Building Technologies, Inc.