

VA-7450 Electronic Terminal Unit Valve Actuator

Introduction

The VA-7450 Series provides floating or proportional control in HVAC (Heating, Ventilating, and Air Conditioning) applications. The compact design of this actuator makes it suitable for installation in confined spaces, such as fan coil applications.

The VA-7450 series actuator is designed for field mounting onto VG5000 and VB5040-S forged brass valves (see pertinent bulletin).



VA-7450 microprocessor-based actuator with VG5000 (left) and VB-5040-S (right) valves

Features and Benefits

<input type="checkbox"/> Automatic calibration	Simplifies installation; requires no calibration
<input type="checkbox"/> Selectable linear or equal percentage characteristic	Provides optimal control function
<input type="checkbox"/> Compact design	Allows installation in confined spaces (fan coils, etc.)
<input type="checkbox"/> Can be mounted after valve body is installed	Simplifies installation; allows application flexibility
<input type="checkbox"/> Actuator can be rotated after mounting	Provides easier wiring by locating the wiring entry in any direction
<input type="checkbox"/> Periodic full cycle (anti-sticking) option	Keeps plug and seat clear of impurities
<input type="checkbox"/> LED operating status display	Reduces the commissioning time and display operating status
<input type="checkbox"/> Motor Time-out Feature	Provides higher reliability by deactivating the actuator motor at ends of stroke

Ordering data

VA-7450-1001

3-point actuator, 24 VAC power supply

VA-7452-1001

0..10 VDC input actuator

Fixed settings: no anti-sticking, linear characteristic, direct action

VA-7452-9001

Configurable actuator with voltage input 0..10, 0..5 or 5..10 VDC

See "Adjustments" for more information.

Special models with other cable lengths are available on request.

Actuator combinations

The VA-7450 series electronic valve actuators are designed to be used with the VG5000 and VB-5040-S valve series. An adapter is required when used in combination with VB-5040-S valve series. The ordering data for these valve bodies and adapters are as follows:

● VG5000 series

VG52 □ 0 □ C 2-way Push Down To Close (Normally Open) series

VG54 □ 0 □ C 2-way Push Down To Open (Normally Closed) series

VG55 □ 0 □ C 3-way mixing with built-in Normally Open bypass

VG58 □ 0 □ C 3-way mixing

Option: VA-7450-8900 manual override accessory (See "Dimensions")

Please refer to the product bulletin "VG5000 Forged Brass Valves" for complete ordering information.

● VB-5040-S series (male connections)

VB-5440-S □ □ □ □ 2-way Push Down To Open (Normally Closed) series

VB-5540-S □ □ □ □ 3-way with built-in Normally Open bypass series

VB-5840-S □ □ □ □ 3-way mixing



VB-5000-8045 Adapter set to be ordered separately (pack of 10)

Please refer to the product bulletin "VB-5040-S Forged Brass Valves ½" and ¾" male thread" for complete ordering information.

Operation

Floating models (VA-7450-xxxx series)

See also VG5000 or VB-5040-S product bulletins for valve operation.

Red cable energised		Actuator stem extends
White cable energised		Actuator stem retracts

When the signal is applied to the Blue and Red wires, the actuator motor drives to gear assembly, and pushes down on the valve stem against the force of the valve return spring. When the signal is removed, the actuator remains in position.

The signal remain applied to the Up or Down wire, the actuator will time out and shut off the motor after approximately 80 seconds.

End of stroke Confirmation: When the signal is applied continuously in the same direction, the actuator turns on every 2 hours and drives in the signal direction for approximately 80 seconds to confirm the end of stroke position.

Proportional models (VA-7452-xxxx series)

See also VG5000 or VB-5040-S product bulletins for valve operation.

The VA-7452-1001 has fixed settings (see curve ① below)

①

The VA-7452-9001 is configurable:

Jumper 5 "Direct Action" 

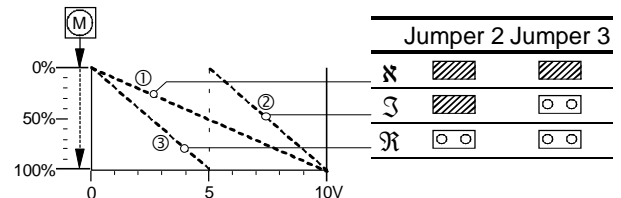

Jumper 5 "Reverse Action" 

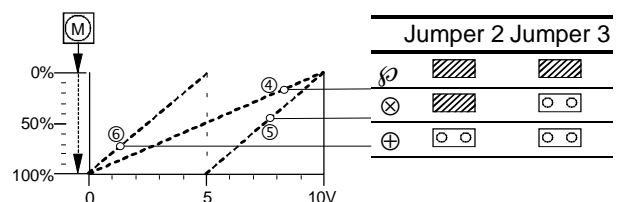

When the signal increases in Direct Action (DA) configuration or decreases in Reverse Action (RA) configuration, the actuator motor drives the gear assembly, and pushes down on the valve return spring.

When the signal decreases in DA configuration or increases in RA configuration, the actuator retracts and allows the valve return spring to move the valve stem in the direction of its normal position or up.

End of Stroke Confirmation: When the input signal is at 0 or 100% continuously, the actuator turns on every 2 hours and drives in the signal direction for approximately 80 seconds to confirm the end-of-stroke position.

Auto-Zero Calibration: when the power is applied, the actuator self-calibrates to the full stroke end position by performing a complete cycle. The actuator drives in the stem down direction for approximately 80 seconds, then drives to the input signal command position.

Anti-Sticking Cycle: When the anti-sticking cycle is enabled (On), the actuator performs one complete cycle every 24 hours to clear possible accumulation of impurities from the valve plug and seat. The anti-sticking feature is jumper selectable, (see page 4).

Characteristic: the actuator can be set to perform linear or equal percentage flow characteristic when used in combination with VG5000 valves series.

Valve Selection: the actuator is factory set for use with 2-way Push Down to Close (PDTC) VG5200 valves. For 2-way Push Down To Open (PDTO) VG5400 valve applications, change the valve normal position jumper to PDTO. For 3-way VG5000 valve applications, set the valve body type jumper to 3-way and set the valve normal position jumper to correspond to the service port of the valve (See Adjustments Jumper setting on page 4).

Setting the Valve normal position jumper

Operating display

LED Indication		
On		Power line present, motor not running (*)
Single Blinking		Motor running
Double Blinking		End-of-stroke confirmation cycle or anti-sticking cycle
Off		Power line not present

(*) Note: Proportional model: when in control.
Floating model: time out, motor not running.

Valve Action Summary

See "Operation" for information about spindle movement.

Valve Code	Valve Type	Stem movement / flow	= flow	= no flow
VG52x0xC	 2-way NO, PDTC *)	Actuator spindle down	Actuator spindle up	
VG54x0xC VB-5440-Sxxxx	 2-way NC, PDTO *)	Actuator spindle down	Actuator spindle up	
VG55x0xC VB-5540-Sxxxx	 3-way + NO ByPass	Actuator spindle down	Actuator spindle up	
VG58x0xC VB-5840-Sxxxx	 3-way, mixing	Actuator spindle down	Actuator spindle up	

Mounting instructions

When mounting the actuator on a VG5000 or a VB-5040-S valve, please follow the instructions below:

Mount the VB-5000-8045 adapter set when used with VB-5040-S only (steps ①, ②, ③)

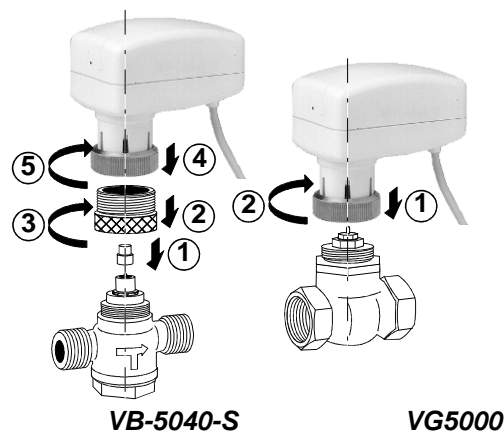

- Never use the actuator as a mounting lever.
- Mounting position:

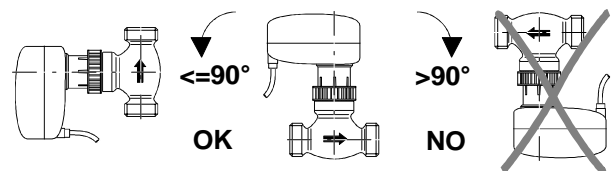

Wiring instructions

WARNING

When servicing make sure that:

- the electric supply to the actuator is switched off to avoid possible damage to the equipment, personal injury or shock.
- you do not touch or attempt to connect or disconnect wires when electric power is on.

When wiring the actuator, please follow the instructions below:

- Before mounting, wiring or adjusting the actuator, make sure that the power supply has been disconnected to avoid possible harm to material or person.
- Make sure that the line power supply is in accordance with the power supply specified on the actuator.
- All wiring should conform to local codes and must be carried out by authorised personnel only.

Wiring Diagrams

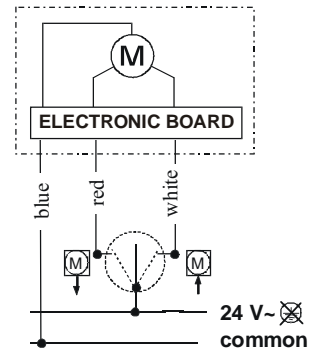

Incremental model

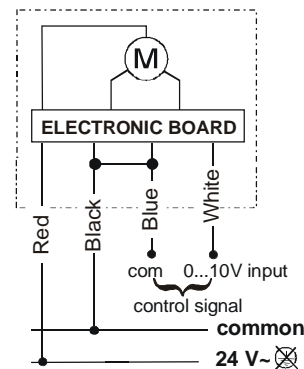

Proportional model

This is how the jumpers are positioned on the board:

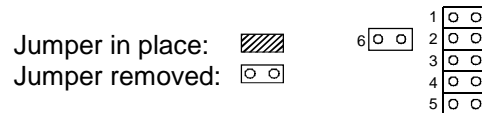

Adjustments (Jumper settings)

(For proportional models only).

VA-7452-1001 has FIXED settings (the jumpers are NOT accessible)

VA-7452-9001 is fully configurable

Function	Jumper No.	VA-7452-9001 (adjustable)		VA-7452-1001 (fixed settings)
		Factory setting	Alternative setting	
Anti-sticking	1	active	not active	not active
Input control signal	2	0..10V	5..10V 0...5V	0...10 V
	3			
Flow characteristic *)	4	linear	equal percentage (VG5000 only)	linear
Action	5	Direct (DA)	Reverse (RA)	Direct (DA)
Body type	6	2-way PDT0 (NC) and 3-way Normally Closed port	2-way PDT0 (NO) valve bodies	2-way PDT0 (NC) and 3-way Normally Closed port

*) In combination with VB-5040-S valve bodies, Jumper 4 must be set to linear . On VG5000 series with Kvs 0,25 and 0,4 . These is always quick characteristic independent from jumper setting.

Dimensions (in mm)

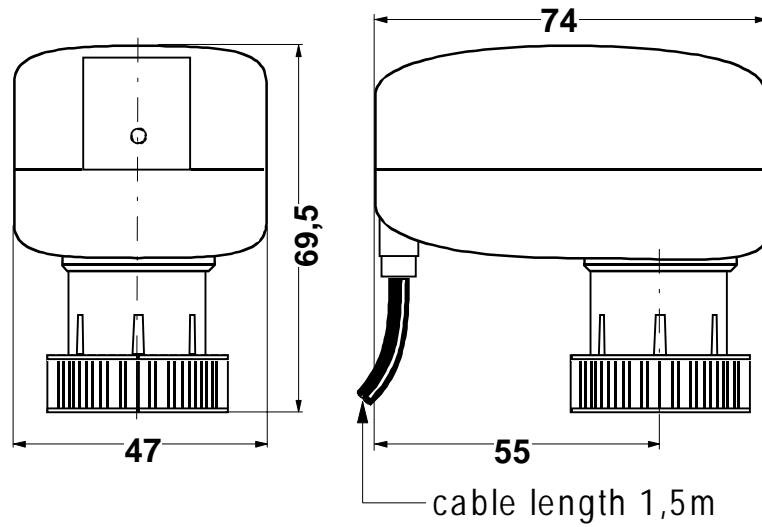

VA-7450 actuator

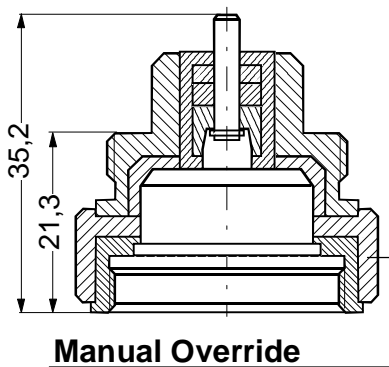

Manual Override

Turn approx. 90
for max. stroke.

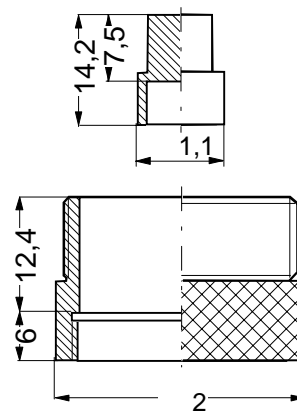

Adapter set VB-5000-8045 for combination with
VB-5040-S valve bodies

VA-7450-8900 manual override ring accessory (optional) for combination with VG5000 valve bodies.

It is used to manually open PDTO valves or the Normally Closed port of 3-way valves. It is to be mounted between the valve and the actuator.

Note: The manual override ring will not fully close PDTC valves or the Normally Opened port or 3-way valves.

Specifications

Models:	VA-7450-1001	VA-7452-1001: fixed settings VA-7452-9001: configurable
Action/Control:	Incremental (floating or PAT)	Proportional (0...10 V, 0...5 V or 5...10 V)
Supply voltage (50/60 Hz):	24 VAC \pm 15%	
Input impedance:	-	80 k Ω
Power consumption:		
Apparent	5 VA at max. power supply	
Active	2,5 W	
Nominal force:	120 N +30% / -20 %	
Maximum stroke:	5 mm	
Full stroke time:	45 seconds for 3 mm stroke	
Protection:	IP40 (EN 60529)	
Connection to Valves:	M28x1,5 for VG5000 series valves	
Ambient Operating condition:	0 to +50 °C, non condensing	
Ambient Storage condition:	-20 to +65 °C, non condensing	
Electrical connections:	1,5 m long flexible cable, \varnothing 4,5 mm	
Operating status:	LED display	
Shipping Weight:	0,18 Kg	
CE Compliance:	EMC (89/336 EEC) according to the standard EN 50081-1 and EN 50082-1	

*The performance specifications are nominal and conform to acceptable industry standards. For application at conditions beyond these specifications, consult the local Johnson Controls office.
Johnson Controls, Inc. shall not be liable for damages resulting from misapplication or misuse of its products.*