



HAPC Series-EMF9201 series electromagnetic flow meter

Description

EMF9201 electromagnetic flow meter are suitable for measuring the flow of almost all electrically conducting liquids, as well as sludges, pastes and slurries. A prerequisite is that the medium must have a certain minimum conductivity. The temperature, pressure, viscosity and density have no influence on the result.

Even corrosive media can be measured providing suitable materials are selected for the tube liner and the electrodes. Solids present in the medium do not usually influence the result. The flow sensors are combined with the intelligent converters Integrated/separate to produce a complete unit.

Application

The main applications of the EMF9201 series flow meter can be found in the following fields:

- ⌘ Water, waste water
- ⌘ Power generation and distribution
- ⌘ Chemical and pharmaceutical industries
- ⌘ Food industry and HVAC Plant

Featuring

The measurement of flow is in a close circuit with water using an electromagnetic principle with higher accuracy compared to ultrasonic series. Important properties are:

- ⌘ **Non-wearing due to non-moving parts**
- ⌘ **Measuring range of flow 1:100, 1:1000 total range**
- ⌘ **No settling sections or flow strengtheners**
- ⌘ **Applicable for measuring the flow-rate of various conducting liquid**
- ⌘ **Measured result is not influenced by physical characteristics**
- ⌘ **Strong corrosive and abrasive**
- ⌘ **Bi-direction flow measurement**
- ⌘ **Large , easy to use liquid-crystal display / HMI**
- ⌘ **Non-volatile EEPROM for secure storage of set-up parameters and measured data**
- ⌘ **Support MODBUS/HART communication protocol**
- ⌘ **Demand measurements with maximum values**
- ⌘ **High or low flow rate alarm**
- ⌘ **Self-diagnostics**

Measuring principle

The working principle of the electromagnetic flow meter is based on Faraday's Law of electromagnetic induction:

When a conductive liquid passes through a measuring pipe surrounded by a magnetic field an electromotive force (EMF) will be induced perpendicular to the direction of flow of the conductive liquid. The induced EMF is in proportion to the average flow rate.:

Utilizing this law the converter provides excitation current to a loop inside the sensor. Thus, a magnetic field is produced inside the measuring pipe of the sensor. The conductive liquid passing through the measuring pipe produces an EMF as a result of cutting the magnetic lines of force

Electrodes placed on opposing sides of the measuring pipe receive this EMF and transfer it to the converter through a signal cable. After filtering, amplifying and calculation by the converter, the flow rate of the measured media is obtained. Finally, a standard current or frequency signal, directly proportion to the measured flow rate, is made available for external process control or monitoring.

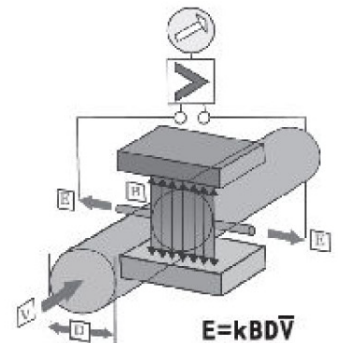

Technical data

Display	LCD display of various flow data with up to 8 digits, m³/h or l/s display unit optional
Product structure	In-line type design, Integrated or separate type
Measured media	Liquid and solid-liquid two-phase fluid with conductivity > 0.5 $\mu\text{s}/\text{cm}^2$
Measuring range	0.15 m/s ~ 15 m/s optional
Measuring accuracy	The accuracy is $\pm 0.5\%$ for any measured velocity in full scale range The accuracy is $\pm 0.3\%$ in 0.5 m/s ~ 10 m/s scale range is optional
Diameter (mm)	15 ~ 1200 mm, maximum 2000 mm on request
Nominal pressure	PN10, PN16, PN25 or PN40 optional
Electrode material	Stainless steel 316L or Ti, others on request (e.g. Hc, Hb, Ta, W)
Lining material	Ne, FEP or PTFE optional
Media temperature	0 ~ 70 °C. Maximum 180 °C on request (note: Temperature limitation relate to the thermal characteristics of the lining materials)
Output signal	4 ~ 20 mA or frequency
Communication	Optional, support MODBUS or HART communication protocol
Connection	Flange type connection for size from DN15 ~ DN2000
Connection standard	Flanges may be provided to suit various standards (e.g. BS EN1092-2, ISO 7005-2, BS4504, HG20593-199, GB9119)
Certificate of CE	According to LVD 2006/95/EC and EMC 2004/108/EC EN 61326-1:2006, Emission (Conformity to EN61000-6-4) EN 61326-1:2006, Immunity (Conformity to EN61000-6-1) EN61000-3-2:2006 Limits for Harmonic Current Emissions EN 61010-1:2001, Safety – Part 1: General requirements
Protection class	IP65 for integrated type, IP67 or IP68 optional for separate type
Power supply	AC220V or DC24V optional
Ambient temperature	5 ~ 55 °C
Ambient humidity	< 85 % R.H. (non-condensing)

Electromagnetic flow sensor



Fig.1 MF01 flange type flow sensor and separate converter

The shell of the flow sensor is welded with carbon steel. The electrode and lining are contacted with the liquid. The flow sensor and the converter may be one compact set or separately mounted.

Technical data of flow sensor

Application range	Including all conductive liquid such as HVAC cold and hot water, fresh water, various corrosive media.
Diameter (mm)	15~1200mm, maximum 2000mm on request
Nominal pressure	PN10, PN16, PN25 or PN40 optional
Electrode material	Stainless steel 316L or Ti, others on request (e.g. Hc, Hb, Ta, W)
Lining material	Ne , FEP or PTFE optional
Media temperature	0~70°C. Maximum 180°C upon request (note: temperature limitation relates to the thermal characteristics of the lining materials)
Shell material	Carbon steel for flow sensor, others on request (e.g. stainless steel 304)
Protection class	IP67 or IP68 optional for flow sensor
Connection standard	Flange may be provided to suit various standards (e.g. BS EN1092-2 , ISO 7005-2, BS4504, HG20593-199, GB9119)

Dimensions

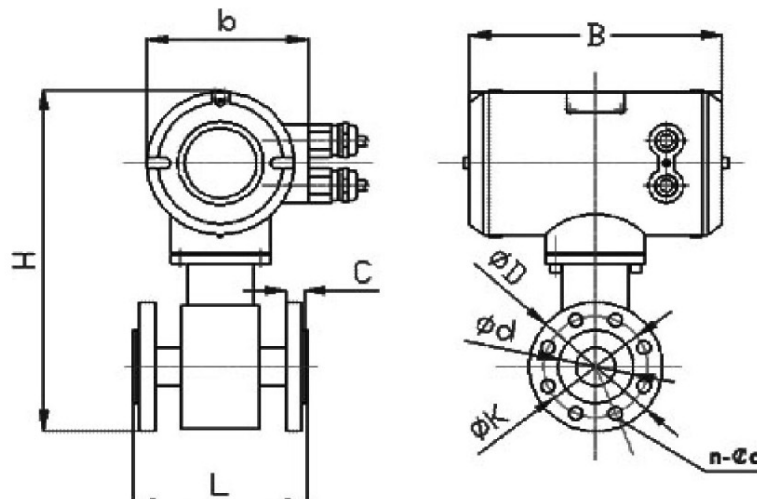

Technical data of flange type meter

DN mm	Lining materials			Flow range selection Flow volume (m ³ /h)			Overall dimensions(mm)				Connection dimensions (mm)			
	Ne	FEP	PTFE	Norm. Flow	Min. flow	Max. flow	L	H	B	b	φK	n-φd	φD	φd
15		•		1.5	0.03	3	160	304	189	152	65	4-φ14	95	46
20		•		2.5	0.05	5	160	304			75	4-φ14	105	56
25		•		3.5	0.07	7	160	304			85	4-φ14	115	65
32		•	•	6	0.12	12		320			100	4-φ18	140	76
40		•	•	10	0.2	20	200	330			110	4-φ18	150	84
50	•	•	•	15	0.3	30		344			125	4-φ18	165	99
65	•	•	•	25	0.5	50		363			145	8-φ18	185	118
80	•	•	•	40	0.8	80		376			160	8-φ18	200	132
100	•	•	•	60	1.2	120	250	394			180	8-φ18	220	156
125	•	•	•	100	2	200		422			210	8-φ18	245	184
150	•	•	•	150	3	300	300	453			240	8-φ22	285	211
200	•	•	•	250	5	500	350	510			295	12-φ22	340	265
250	•	•	•	400	8	800	400	561			355	12-φ26	405	319
300	•	•	•	600	12	1200	500	615			410	12-φ26	460	370
350	•		•	750	15	1500		670			470	16-φ26	520	429
400	•		•	900	18	1800	600	725			525	16-φ30	580	480
450	•		•	1200	24	2400		777			585	20-φ30	640	548
500	•		•	1500	30	3000		832			650	20-φ32	715	609
600	•		•	2500	50	5000		832			770	20-φ36	840	720
700	•			4000	80	8000	700	1118			840	24-φ36	910	794
800	•			5000	100	10000	800	1207	950	24-φ39	1025	901		
900	•			6000	120	12000	900	1280	1050	28-φ39	1125	1001		
1000	•			8000	160	16000	1000	1382	1170	28-φ42	1255	1112		
1200	•			10000	200	20000	1200	1642	1390	32-φ48	1485	1328		

Remark

- 1) For DN80 or below the standard nominal pressure is PN40
 DN100~DN300 PN16 or PN25 options
 DN350~DN600 or higher is options
- 2) If the pressure required is higher than choices stated in 1) above, please specify the required pressure rating at time of ordering

Converters

EMF9201 intelligent type converter designed on the basis of microprocessor technology has all kinds of performance and advantages of intelligent instrument, such as simple structure, stable and reliable.

EMF9201 intelligent type converter adopts lightning protection circuit so it can be made to survive rough conditions. The converter can detect many kinds of fault automatically and if detected any one then display the alarm on the LCD screen.

Permanent memory

The LOG of the converter records the following values: current instantaneous flow, power on/power off information, cumulated forward/reverse flow and max value.

Cumulated forward/reverse flow record the totally cumulated value till now. Max. instantaneous flow is stored for a further 36 months (monthly), and 15 years (yearly), power on/off information is stored for 50 items in a record for possible subsequent study of operating conditions in the system.

Note: Max. instantaneous flow is option function, only for RS485 communication mode

Display description

The calculator has an easily-read LCD display with up to 8 digits and associated icons for ease of interpretation of the related display information. The following data is displayed

Instantaneous flow, forward/reverse cumulated volume and alarm information. The permanent memory log data may also be displayed.

The structure of converter panel

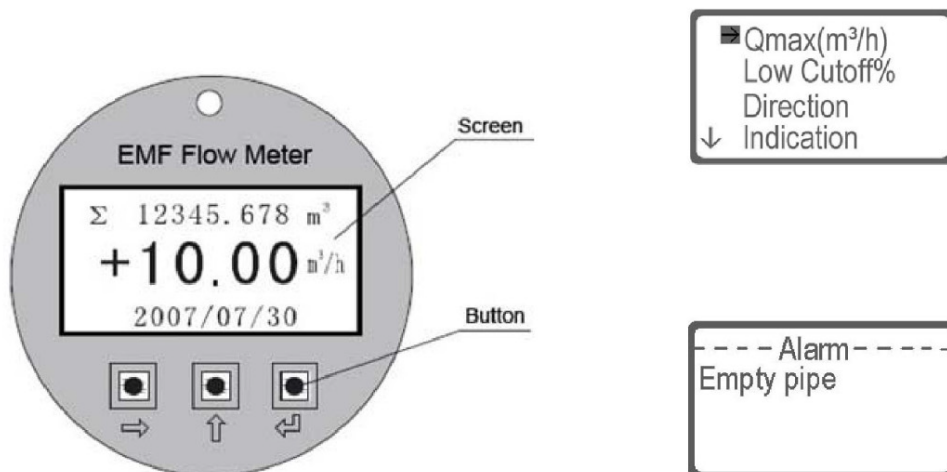

Communication

EMF9201 intelligent type converter support two communication mode:

RS485 communication mode

Open MODBUS communication protocol

HART communication mode

Also support HART communication protocol

You can read all the permanent memory data and other information in this mode such as Instantaneous flow, accumulated flow.

Technical data of converter

Current output	4~20mA
Frequency output	<p>Passive pulse:</p> <p>high level = external power source-1V, external power source voltage should be ≤ 30 V</p> <p>low level ≤ 0.5V</p> <p>load current ≤ 50 mA</p> <p>The maximum frequency output is 5KHz.</p> <p>Note1: When configured as pulse output, the pulse output frequency can be 0~5Hz.</p> <p>Note2: The level output for forwarding/backwarding flow rate, The high or low flow rate alarm is optional.</p>
Display	LCD display at most 8 digit with backlight
Display unit	m^3/h , m^3/m , m^3/s , L/h, L/m, L/s, G/h, G/m, G/s display unit optional for instantaneous flow. m^3 , L, G display unit optional for cumulated flow.
Communication	Optional, support MODBUS or HART communication protocol
Power supply	220Vac $\pm 10\%$ 50Hz or 24Vdc, max.15VA
EMC emission	EN 61326-1:2006, Emission (Conformity to BS EN61000-6-4)
EMC immunity	EN 61326-1:2006, Immunity (Conformity to BS EN61000-6-1)
Limits for Harmonic Current Emissions	Compliance to EN 61000-3-2:2006
CE product safety	EN 61010-1:2001, Safety – Part 1:General requirements
Protection class	IP65
Ambient temperature	5~55 °C
Ambient humidity	<85 % R.H. (non-condensing)

Note: frequency output can be configured to show the flow direction is inverse (always output low level voltage) or not (always output high level voltage).

Installation structure

HAPC series-EMF9201 electromagnetic flow meter consists of two types :

Integrated type – converter assembled mounted on the flow sensor directly
 Separate type – converter connects to the flow sensor with signal cable.

In order to ensure accurate measurement the converter should be fixed on the wall or installed on the sensor's solid support The distance between the converter and the flow sensor should not be more than 10 meters.

Diameter selection

Select the same diameter sensor as that of the process pipeline when the normal velocity of flow in the measured pipeline is more than 0.5 m/s.

Select smaller diameter sensor as that of the process pipeline under the following conditions:

The velocity of flow in the pipeline is such that it can not meet the minimum velocity limit of the flow meter or the measurement precision is not satisfied under the present velocity (the velocity limit to obtain relatively high precision is more than 1m/s)

Electrode materials selection

Materials	Code	Corrosive resistance
Stainless 316L	V	Used in minimal corrosive medium such as industrial water, domestic water, sewage, neutral solution and weak acid such as carbonic acid, acetic acid etc.
Titanium	Ti	Good resistance to seawater, various kinds of chloride, hypochlorite and many kinds of hydroxide
Hastelloy c	Hc	Resistance to oxidation acid, like nitric acid, mixing acid, a mixture of sulfuric acid and chromium, and oxidation salt or other antioxidant environments. Good corrosion resistance for seawater, alkaline solutions or peroxide-based solutions
Hastelloy b	Hb	Good corrosion resistance for oxidizing acid, alkaline, salt sulfuric acid, phosphoric acid, hydrofluoric acid etc.
Tantalum	Ta	Resists almost all the chemical mediums except hydrofluoric acid. Because the price is expensive typically used only for sulfuric acid or hydrochloric acid
Tungsten carbide	W	Excellent wear resistance, dedicated to abrasive mediums such as mud or pulp

Lining materials selection

Lining materials	Corrosive resistance	Working temp.	Range of application
Ne	Neoprene Resists low concentration acid alkali salts	0~70°C	Industrial water, sewage, low concentration acid alkaline salt solution. Maximum 95°C on request. Ne lining materials can only be selected for DN50~DN2000.
FEP	Fluorinated ethylene propylene Heat resistant and corrosion resistant High mechanical strength, abrasion resistant and durable during cleaning process	-20~120°C	All fluids except high abrasive mediums like mortar. Suitable for use with drinking water. Maximum 180°C on request. FEP lining materials can only be selected for DN15~DN300
PTFE	Polytetrafluoro ethylene Resists corrosion in almost all chemical mediums. Low wear resistance.	-40~180°C	Should not be used in pipes at negative pressure or with highly abrasive mediums. PTFE lining materials can be selected for DN25~DN600

Working Temperature grade selection

The flow sensor has four working temperature ranges; 70°C for general purpose, 95°C and 120°C for high temperatures. The 180°C option is the maximum working range and this option must be specified upon at the time of ordering. For best performance we recommend selecting the temperature closest to the actual working temperature of the medium. I.e. temperature of the medium is 50°C then select temperature grade 70°C.

Ground ring selection

When the grounding condition of the pipeline is unreliable (including insulated pipelines), ground rings should be provided at both sides of the sensor. If the medium is highly abrasive select the grounding ring with neck that also provides protective function for the lining end.

Communication selection

EMF9201 series converter support two communication mode:

- ⌘ Open MODBUS communication protocol
- ⌘ HART communication protocol

Structure selection

The integrated set is considered the standard choice. Select the separate flow meter configuration when the meter is installed underground, in places that may be easily flooded by water, select IP 67 or IP68. When the flow meter is installed in high or low temperature pipelines, or highly corrosive environments

Output signal selection

Active frequency output means no external power supply is required to accomplish the output function. Voltage-free frequency output means an external power supply is required to accomplish the output function. The frequency output port can be configured as an alarm output (digital output) to indicate when the direction of flow is reverse (low voltage state) or forward (high voltage state) or pulse output to indicate the rate of flow or accumulated volume. 4-20mA may be used to output the instantaneous flow rate.

Power supply selection

220V AC or 24V DC power supply. 220V AC is standard.

Examples of model code: e.g. EMF9201-100-11001C51

Description: EMF9201 series electromagnetic flow meter consists of intelligent model converter and DN100 flange type sensor. Stainless 316L is used as its electrode materials and Ne is used as lining materials. Its temperature grade is 0~70°C, no need grounding ring, support MODBUS protocol, output signal is 4~20mA and non-active frequency, power supply is AC220V.

Ordering code

EMF9201- { } -



Operation power supply
0 DC24V
1 AC220V

Output signal (Note 3)
0 no need
1 4~20mA
2 active frequency
3 non-active frequency
4 4~20mA + active frequency
5 4~20mA + non-active frequency

Structure (Note 2)
C Integrated type
S Separate type

Communication
0 no need
1 MODBUS protocol
2 HART protocol

Grounding ring
0 no need
1 Standard grounding ring
2 Grounding ring with neck

Temperature grade of flow sensor
0 0°C ~70°C
1 0°C ~95°C
2 -20°C~120°C
3 -40°C~180°C

Lining materials (Note 1)
1 Ne
2 FEP
3 PTFE

Electrode material
1 Stainless steel 316L
2 Titanium
3 Others(e.g. Hc, Hb, Ta, W)

Flow meter diameter
e.g. 15...1200,2000

Note1 : Ne lining materials can be chose for DN50~DN2000,FEP lining materials only for DN15~DN300,PTFE lining materials can be chose for DN32~DN600.

Note2: When selecting the separate flowmeter give out details about the length(m) of the signal cable of the converter and sensor. The default value is 10 m.

Note3: The frequency output to indicates the value Of the instantaneous flow or the cumulate flow. It can be configured as alarm output to indicate the direction of the flow, the high or Low flow rate alarm is optional.

