

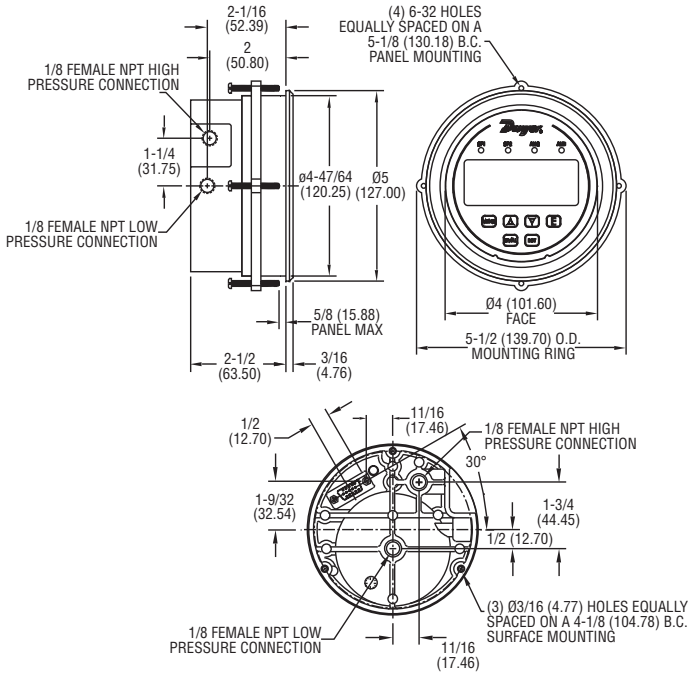

Series DH3 Digihelic® Differential Pressure Controller
Specifications - Installation and Operating Instructions



DIMENSIONS



SPECIFICATIONS

Service: Air and non-combustible, compatible gases.

Wetted Materials: Consult factory.

Housing Material: Die cast aluminum case and bezel.

Accuracy: $\pm 1.5\%$ for 0.25" and ± 0.25 " w.c. ranges. Ranges 0.5" to 5" w.c. and corresponding bi-directional (except ± 2.5 " w.c.): $\pm 1\%$; All other ranges: $\pm 0.5\%$ @ 77°F (25°C) including hysteresis and repeatability (after 1 hour warm-up).

Stability: $< \pm 1\%$ per year.

Pressure Limits: Ranges ≤ 2.5 " w.c.: 25 psi; ± 2.5 ", 5" w.c.: 5 psi; 10" w.c.: 5 psi; 25" w.c.: 5 psi; 50" w.c.: 5 psi; 100" w.c.: 9 psi.

Temperature Limits: 32 to 140°F (0 to 60°C).

Compensated Temperature Limits: 32 to 140°F (0 to 60°C).

Thermal Effects: 0.020%/°F (0.036/°C) from 77°F (25°C). For 0.25" and ± 0.25 " w.c. ranges: $\pm 0.03\%/^{\circ}\text{F}$ ($\pm 0.054\%/^{\circ}\text{C}$).

Power Requirements: 12-24 VAC/VDC.

Power Consumption: 3 VA max.

Output Signal: 4-20 mA DC into 900 ohms max.

Zero & Span Adjustments: Accessible via menus.

Response Time: 250 ms (dampening set to 1).

Display: Backlit 4 digit LCD 0.4" height LED indicators for set point and alarm status.

Electrical Connections: 15 pin male high density D-Sub connection. 18" (46 cm) cable with 10 conductors included.

Process Connections: 1/8" female NPT. Side or back connections.

Mounting Orientation: Mount unit in vertical plane.

Size: 5" (127 mm) O.D. x 3-1/8" (79.38 mm).

Weight: 1.75 lbs. (794 g).

Agency Approvals: CE.

SWITCH SPECIFICATIONS

Switch Type: 2 SPDT relays.

Electrical Rating: 1 amp @ 30 VAC/VDC.

Set Point Adjustment: Adjustable via keypad on face.

INSTALLATION

LOCATION: Select a clean, dry location free from shock and vibration where temperature limits will not be exceeded. Distance from the transmitter to the receiver is limited only by total loop resistance. See ELECTRICAL CONNECTIONS. Tubing feeding pressure to the instrument can be practically any length required, but long lengths will increase response time slightly.

POSITION: All standard models are calibrated for use in a vertical mounting position. Higher range models will perform properly at other angles but should be spanned and zeroed in the position in which they will be used. Because of their sensitivity to gravitational forces, models with ranges under 1" w.c. (25.4 mm w.c.) must always be mounted vertically.

PRESSURE CONNECTIONS: For installation convenience two sets of 1/8" female NPT pressure ports are supplied. Be sure to seal the unused ports with pipe plugs included.

Positive Pressure - Connect tubing to HIGH PRESSURE port and vent LOW PRESSURE port to atmosphere.

Negative (Vacuum) Pressure - Connect tubing to LOW PRESSURE port and vent HIGH PRESSURE port to atmosphere. (When operating this device in a dusty environment, install an optional A-331 Filter Vent Plug in the vented port to keep interior clean.)

Differential Pressure - Connect tubing from the higher source to HIGH PRESSURE port and from the lower source to LOW PRESSURE port.

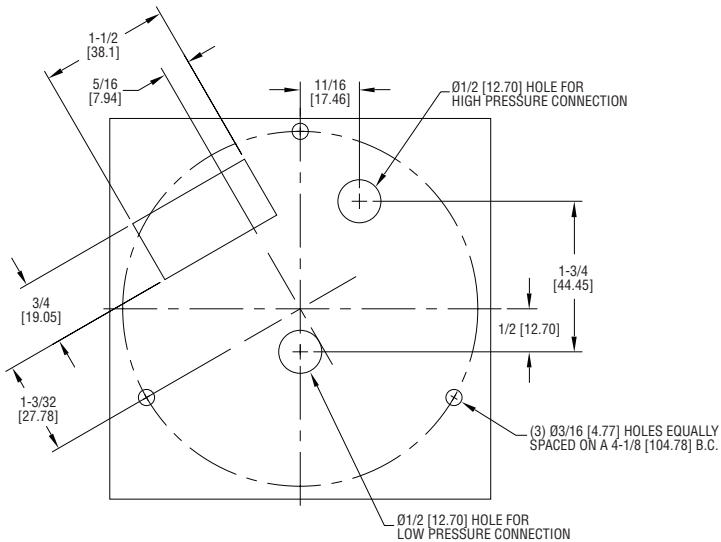

Fig. A

MOUNTING: The DH 3 may be either panel (flush) mounted or surface mounted.

Panel Mounting - Cut a 4-13/16" or 122 mm diameter hole in the panel and insert the unit from the front. Slip on the mounting ring with the stepped side facing rear. Next, fit the snap ring into the narrow groove at back edge of bezel. Thread four (6) 32 x 1-1/4" mounting screws into tapped holes in mounting ring and set it against snap ring. Tighten screws against rear of panel. See Fig. B.

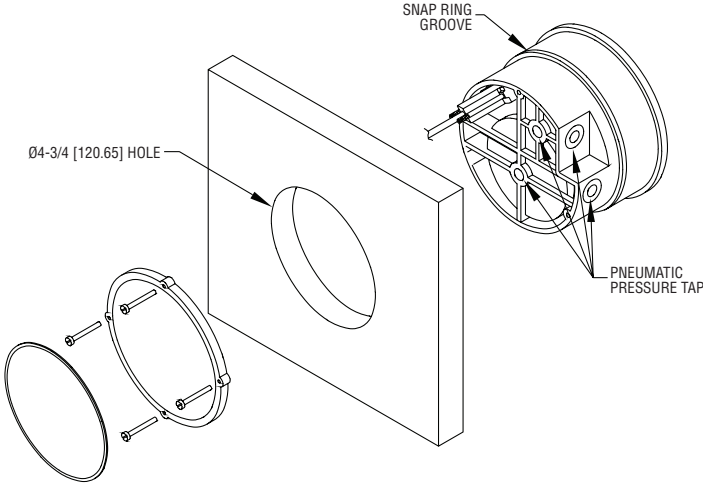

Fig. B

Surface Mounting - Drill (3) 3/16" (4.76 mm) diameter holes for mounting and cut a 9/16" x 1-1/2" (14.3 x 38.1 mm) opening for access to terminal block as indicated in Fig. B. If rear pressure connections are to be used, also provide 1/2" diameter holes as shown in Figs. A and C. Insert 6-32 machine screws from rear of mounting surface, thread into tapped holes on back of transmitter and tighten.

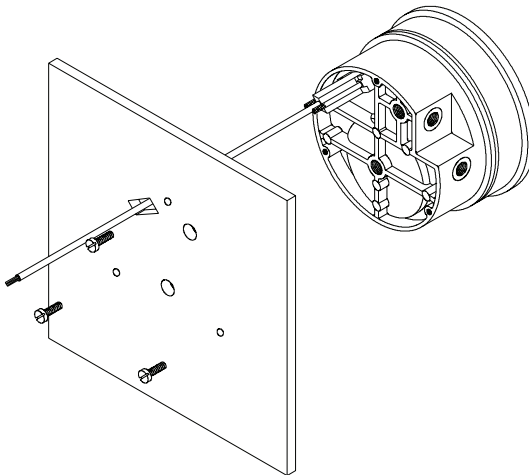

Fig. C

WIRING

The DH 3 uses a standard 15 pin male high density D-Sub connector available from most electronic distributors. A pre-wired 18" cable is included with each unit. See below table for cable color wiring information.





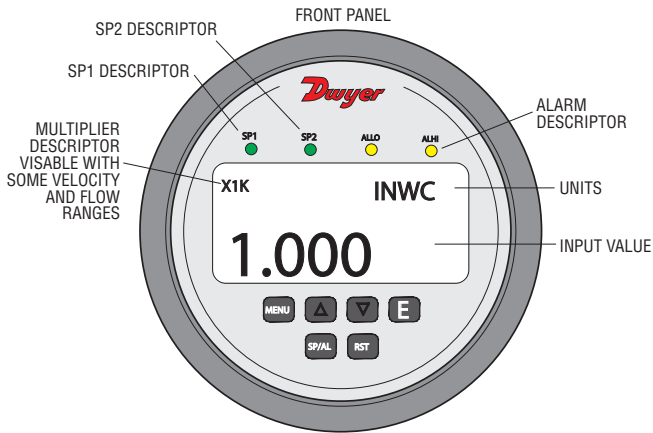

Function	15 PIN Connector Terminal	Cable Color
12-24 VAC/VDC Power	1	Brown
12-24 VAC/VDC Power	6	Yellow
4-20mA XMTR Output -	2	Black
4-20mA XMTR Output +	11	Red
SP1 Relay N/O	12	Violet
SP1 Relay Com	13	Grey
SP1 RELAY N/C	14	White
SP2 or ALarm Relay N/O	15	Blue
SP2 or ALarm Relay Com	10	Green
SP2 or ALarm Relay N/C	5	Orange

NOTES:

1. If 12-24 VDC power is used, the polarity is unimportant.
2. Wire in accordance with an equivalent national standard or code. Use copper conductors only rated for 60°C.
3. All terminals are rated CLASS 2.
4. ISOLATION: All inputs and outputs to each other: 500 VAC.
5. 4-20 mA Transmitter – Check the specifications for the device receiving this signal for input resistance. Typical 250 to 600 OHMS, 600 OHMS maximum.



KEY FUNCTIONS

	Home Position Function	Main Menu Function	Sub Menu Function
 SP/AL	Sequences the display through SET POINT and ALARM settings	Return to home position	Return to home position
 MENU	Allows access to the menus	Return to home position	Return to previous menu
 UP ARROW		Sequences through menus	Increments a value
 DOWN ARROW		Sequences through menus	Decrements a value
 ENTER	Displays full scale range of unit	Enter into SUB MENU	Changes a value or setting. Press ENTER and display will blink. Adjust with UP or DOWN arrows. Press ENTER to store. Display will stop blinking.
 RESET	Clears or resets an Alarm (alarm set for manual reset)		Peak/Valley SUB MENU resets display to present value.

SETTING SET POINTS AND ALARMS

The **SP/AL** hot key provides direct access to the Set Point and Alarm MENU. The Set Point and Alarm MENUS that are displayed are based upon the Control (Ctrl) SUB MENU.

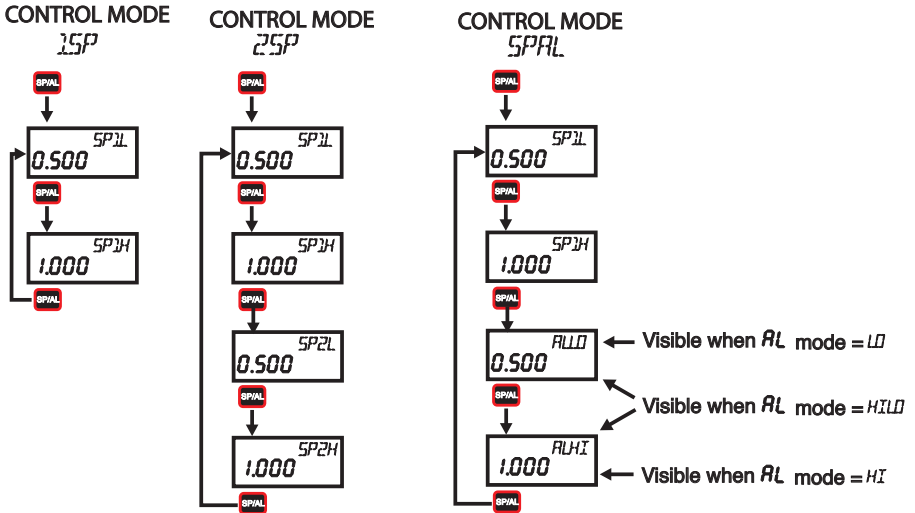

SET POINT ADJUSTMENT

Adjusting the DH[®] 3 Set Points is quick and simple. Instead of setting a set point and dead-band, simply adjust $SP1H$ or $SP2H$ for the desired relay turn on point, and then adjust $SP1L$ or $SP2L$ for the desired relay turn off point.

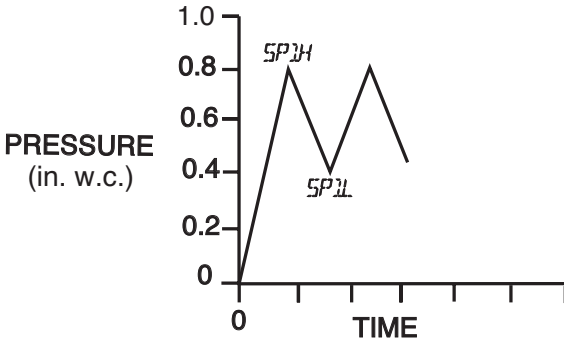

In the above graph, an instrument with a 1.0" range would have the SP1 relay turn on at 0.8" and off at 0.4". $SP1H$ sets the relay turn on point, and $SP1L$ sets the relay turn off point. The relays outputs normally function in the direct acting mode, which means the relays turn on with an increase in pressure. SP1 may be configured to act as a reverse acting relay (refer to the 1SP SUB MENU setting, page 15). When set for reverse acting, $SP1H$ sets the relay turn OFF point, and $SP1L$ sets the relay turn ON point. SP2 is always direct acting.

MENU MAP

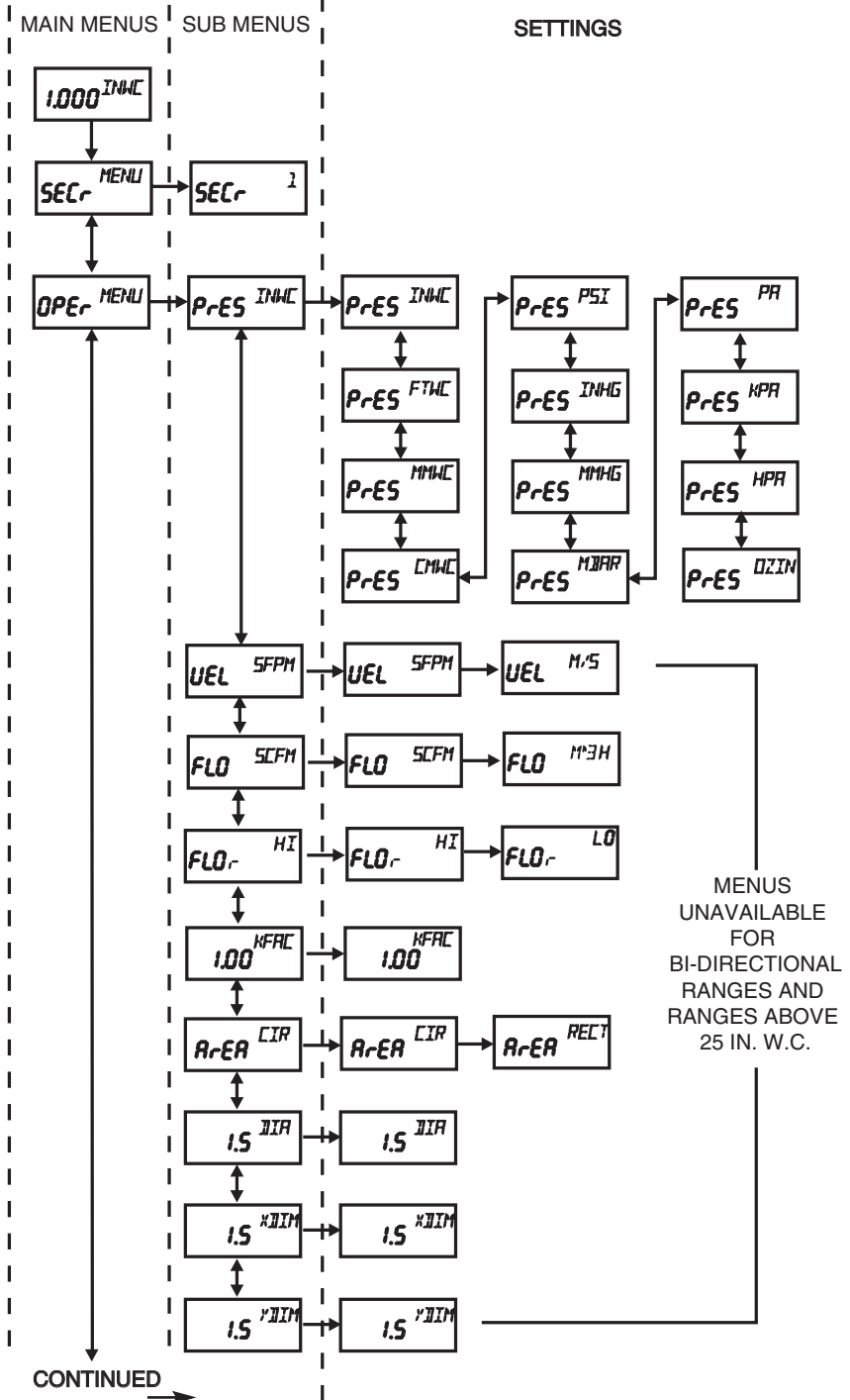

CONTINUED →



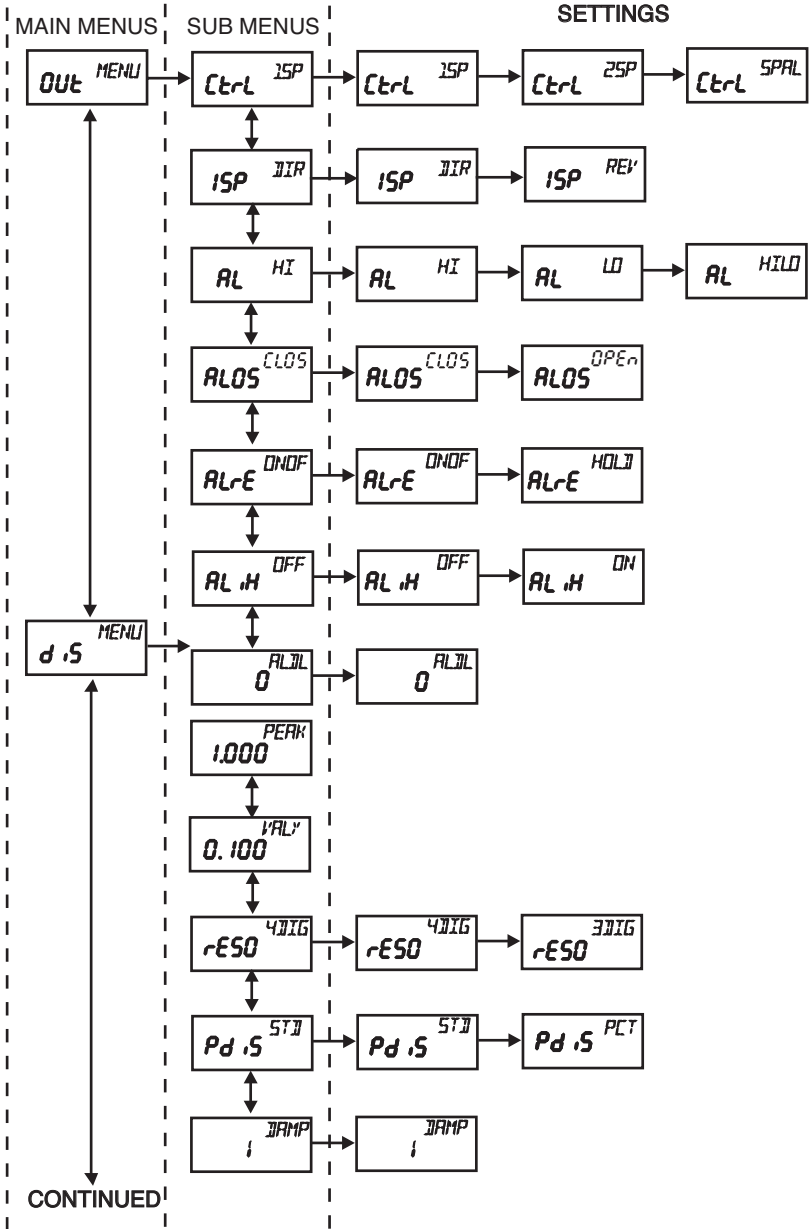

MAIN MENU

SUB MENU

SETTINGS

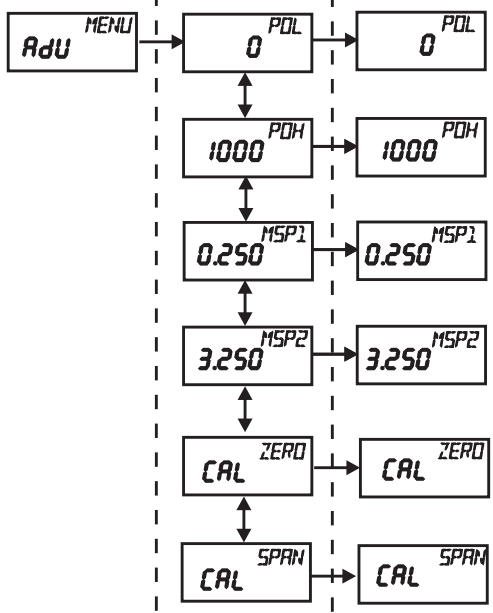

Menus present only in pressure operation



Main Menu Selections (Upper Right Display Reads *MENU*)

SEC Security - Lock out access to Set Point and Alarm settings, or lock out access to all settings.

OPER Operation - Selection of Pressure, Velocity or Flow and corresponding engineering units.

OUT Output - Select a Single Set Point, 2 Set Points, or a Set Point and an Alarm mode of operation.

DIS Display - Monitor and adjust display related settings: Peak, Valley, display resolution, % output and dampening.

ADV Advanced functions - Modify advanced function parameters, transmitter output scaling, Maintenance Set Point settings and calibration.

MAIN MENUS and SUB MENU

SEC- (Security) MAIN MENU

SEC- is the only SUB MENU in the security MENU. When the security SUB MENU is selected, the present security level is displayed in the upper right hand display. To change the security level, adjust the number displayed to the number shown in the following table for the desired security level.

Security Level Displayed	Access	Password Value to Enter
1	All menus access	10
2	Menu Access SP/AL Locked	70
3	SP/AL Access Menus Locked	90
4	All settings locked	111

The password values shown in the table cannot be altered, so retain a copy of these pages for future reference.

OPE- (Operation) MAIN MENU

The OPE- MENU selects the measurement type of the instrument.
The SUB MENUS are:

PRES - Pressure

KFAC - K Factor

XDIM - X Dimension

VEL - Velocity

AREA - Area

YDIM - Y Dimension

FLO - Flow

DIA - Diameter

If the instrument is set for Velocity, the OPE- MENU will have an additional KFAC SUB MENU. If the instrument is set for Flow, the OPE- MENU will have additional KFAC and AREA SUB MENUS. These will be discussed under Velocity and Flow. When scrolling through the OPE- SUB MENUS, the measurement type the unit is currently set for will show the units in the upper right display. The other measurement types will have a blank upper right display.



PRES (Pressure) SUB MENU

For pressure measurement, the following units are available:

INWC - Inches of water column

FTWC - Feet of water column

MMWC - Millimeters of water column

CMWC - Centimeters of water column

PSI - Pounds per square inch

INHG - Inches of mercury

MMHG - Millimeters of mercury

MBAR - Millibar

PA - Pascal

KPA - Kilopascals

HPA - Hectopascals

OZIN - Ounce inches

Table 1 Pressure Range vs. Available Units

INWC	FTWC	MMWC	CMWC	PSI	INHG	MMHG	MBAR	PA	KPA	HPA	OZIN
.1000		2.540	.2540			.1868	.2491	24.91		.2491	
.2500		6.350	.6350			.4671	.6227	62.27		.6227	.1445
.5000		12.70	1.270			.9342	1.245	124.5	.1245	1.245	.2890
1.000		25.40	2.540			1.868	2.491	249.1	.2491	2.491	.5780
2.500	.2083	63.50	6.350		.1839	4.671	6.227	622.7	.6227	6.227	1.445
5.000	.4167	127.0	12.70	.1806	.3678	9.342	12.45	1245	1.245	12.45	2.890
10.00	.8333	254.0	25.40	.3613	.7356	18.68	24.91	2491	2.491	24.91	5.780
25.00	2.083	635.0	63.50	.9032	1.839	46.71	62.27	6227	6.227	62.27	14.45
50.00	4.167	1270	127.0	1.806	3.678	93.42	124.5		12.45	124.5	28.90
100.0	8.333	2540	254.0	3.613	7.356	186.8	249.1		24.91	249.1	57.80

NOTE: *OUF* (over flow) or *UFL* (under flow) will appear when the ranges have been exceeded above or below full scale by 2%.

VEL (Velocity) SUB MENU

For velocity measurement, the following units are available:

SFPM - Standard feet per minute

M/S - Meters per second

Table 2 Available Velocity Ranges

INPUT RANGE	SFPM RANGE	M/S RANGE
0 - 0.1	0 - 1266	0 - 6.431
0 - 0.25	0 - 2002	0 - 10.17
0 - 0.5	0 - 2832	0 - 14.39
0 - 1	0 - 4004	0 - 20.35
0 - 2.5	0 - 6332	0 - 32.17
0 - 5	0 - 8954	0 - 45.48
0 - 10	0 - 12.66 x IK	0 - 64.33
0 - 25	0 - 20.02 x IK	0 - 101.7

NOTE: Air velocity and flow readings are based upon standard dry air conditions with an ambient temperature of 70°F and a barometric pressure of 29.92 INHG.

FLO (Flow) SUB MENU

For flow measurements the following units are available:

SCFM - Standard cubic feet per minute

M³H - Cubic meters per hour

FLO_r (Flow Range) SUB MENU

LO - 99.99 x 1K flow range

HI - 999.9 x 1K flow range

Tables 3-6 show the flow ranges available, and the maximum duct size that can be set for each input range.

Table 3

FLO_r = LO Maximum Duct Size (English)

RANGE IN WC	SCFM RANGE	MAX. DUCT SIZE, SQ. FT.
0.1	99.99 x 1K	78.9
0.25	99.99 x 1K	49.9
0.5	99.99 x 1K	35.3
1	99.99 x 1K	24.9
2.5	99.99 x 1K	15.7
5	99.99 x 1K	11.1
10	99.99 x 1K	7.8
25	99.99 x 1K	4.9

Table 4

FLO_r = HI Maximum Duct Size (English)

RANGE IN WC	SCFM RANGE	MAX. DUCT SIZE, SQ. FT.
0.1	999.9 x 1K	789.8
0.25	999.9 x 1K	499.5
0.5	999.9 x 1K	353.1
1	999.9 x 1K	249.7
2.5	999.9 x 1K	157.9
5	999.9 x 1K	111.7
10	999.9 x 1K	78.9
25	999.9 x 1K	49.9

Table 5

FLO_r = LO Maximum Duct Size (Metric)

RANGE IN WC	M ³ /Hr RANGE	MAX. DUCT SIZE M ²
0.1	99.99 x 1K	4.32
0.25	99.99 x 1K	2.73
0.5	99.99 x 1K	1.93
1	99.99 x 1K	1.37
2.5	99.99 x 1K	0.86
5	99.99 x 1K	0.61
10	99.99 x 1K	0.43
25	99.99 x 1K	0.27

Table 6

FLO_r = HI Maximum Duct Size (Metric)

RANGE IN WC	M ³ /Hr Range	MAX. DUCT SIZE, M ²
0.1	999.9 x 1K	43.19
0.25	999.9 x 1K	27.31
0.5	999.9 x 1K	19.3
1	999.9 x 1K	13.64
2.5	999.9 x 1K	8.63
5	999.9 x 1K	6.10
10	999.9 x 1K	4.31
25	999.9 x 1K	2.73

KFAC SUB MENU

KFAC K Factor - becomes accessible if the instrument is set for Velocity or Flow.

When the DH3[®] is used with a Pitot tube, the manufacturer may specify a K Factor. The adjustment range is 0.01 to 2.00. The factory setting is 1.

AREA, DIA, XDIM and YDIM SUB MENUS

These SUB MENUS become accessible if the instrument is set for flow. When measuring flow, the area of the duct must be specified. Tables 3 and 4 show the input range vs maximum flow and duct size. For a rectangular duct the maximum size is specified in square feet or meters. For a circular duct the maximum size is specified as the diameter. X, Y and circular dimensions are entered in feet with 0.01 foot resolution for $FLOF = LO$ and 0.1 foot resolution for $FLOF = HI$, or entered in millimeters with 1 millimeter resolution.

AREA - Area, select *CIR* for a circular duct or *RECT* for a rectangular duct. If a circular duct is selected, the *DIA* SUB MENU will be activated. If a rectangular duct is selected, the *XDIM* and *YDIM* SUB MENUS will be activated.

DIA - Diameter, enter the diameter of a duct

XDIM - Enter the "X" dimension of a duct

YDIM - Enter the "Y" dimension of a duct

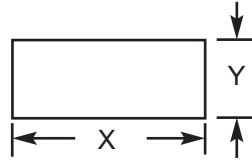

OUT (Output) MAIN MENU

The *OUT* MENU selects the output type of the instrument. The SUB MENUS are:

CTL - Control type

ISP - SP1 reverse or direct acting

AL - Alarm type

ALRE - Alarm reset, manual or auto

ALIH - Alarm inhibit

ALDL - Alarm delay

Ctrl (Control) SUB MENU

1SP - Single set point

2SP - Two fully independent set points

SPAL - Single set point and alarm

1SP (SP1 Reverse or Direct Acting) SUB MENU

DIR - Direct. Relay turns on with increasing pressure

REV - Reverse. Relay turns on with decreasing pressure

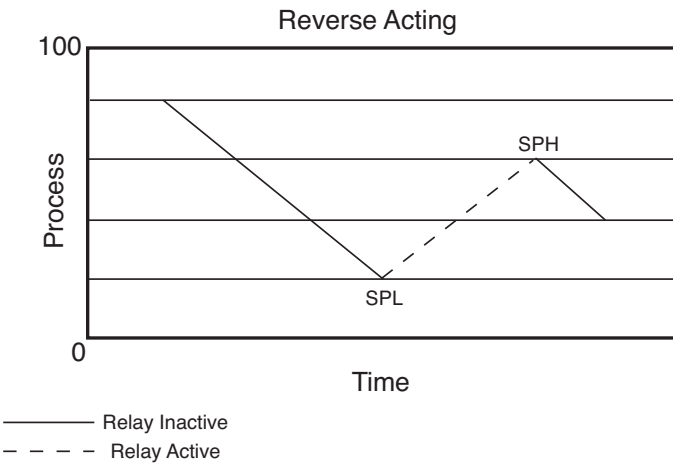
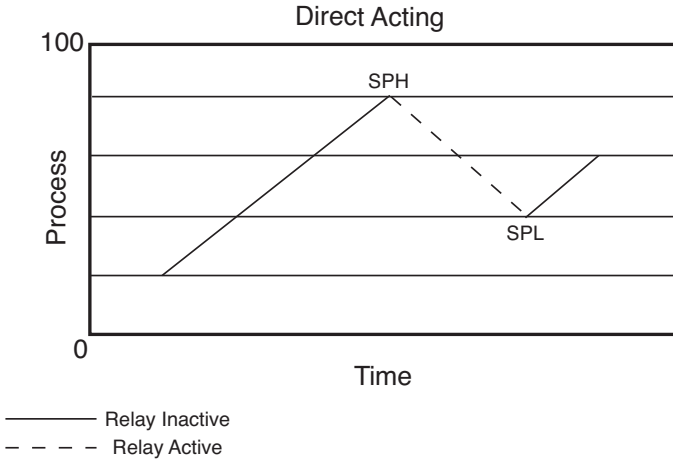

The following alarm function SUB MENUS are activated when $C+-L$ is set to *SPAL*:

AL (Alarm Type) SUB MENU

HI - High alarm

LO - Low alarm

H/LO - For a high/low guardband type alarm

ALARM ADJUSTMENT

Alarm settings are dependent upon the selected alarm mode. The DH3® differential pressure controller alarm may be configured as a High Alarm, Low Alarm, or High/Low Alarm. Alarm settings are all absolute and may be set to anywhere within the range of the instrument. The dead bands of the alarms are fixed at 1% of full scale.

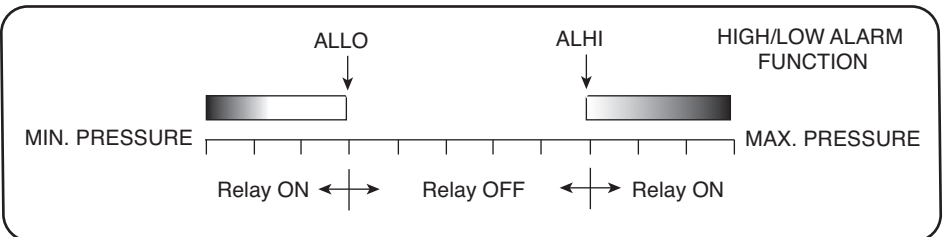
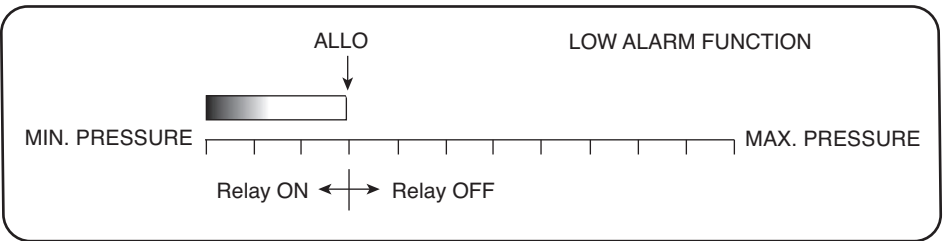
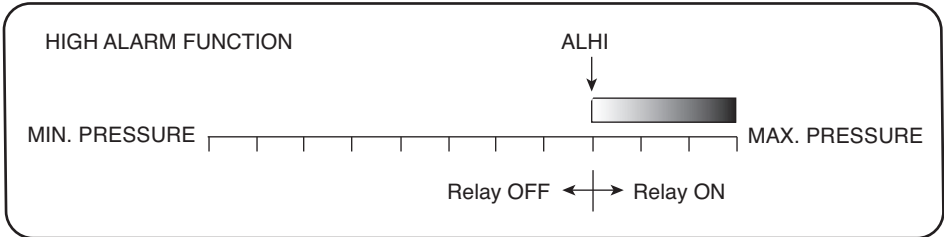

ALOS (Alarm Output State) SUB MENU

CLOS - Alarm relay contacts close upon alarm condition

OPEN - Alarm relay contacts open upon alarm condition

ALrE (Alarm Reset) SUB MENU

DNDF - Automatic reset

HOLD - Manual reset. An alarm is reset by the RESET key on the front panel, or an external reset switch.

ALH (Low Alarm Inhibit) SUB MENU

ON - Alarm inhibit is on

OFF - Alarm inhibit is off

If *ALH* is selected ON, a low alarm condition is suspended upon power up until the process value passes through the alarm set point once.

ALDL (Alarm Delay) SUB MENU

Sets the amount of time an alarm condition must be continuously met before the alarm condition is recognized. The alarm delay is adjustable from 0-3600 seconds.

dS (Display) MAIN MENU

PEAK - Peak value

VAL_v - Valley value

ZERO - Zero

rESD - Resolution

PdS - Process display

DAMP - Dampening level

PEAK (Peak) SUB MENU

The Peak feature stores the highest pressure reading the instrument has measured since the last reset or power up. At power up *PEAK* is reset to the present pressure reading. To manually reset the *PEAK* value, press the RESET key while in the *PEAK* SUB MENU.

VAL_v (Valley) SUB MENU

The valley feature stores the lowest pressure reading the instrument has measured since the last reset or power up. At power up *VAL_v* is reset to the present pressure reading. To manually reset the *VAL_v* value, press the RESET key while in the *VAL_v* SUB MENU.

*R*ESD (Resolution) SUB MENU

The DH 3 is capable of displaying four digits of resolution. However, at very low pressures the instability of the pressure may cause fluctuations in the least significant digit causing the least significant digit to be of little value. Three digit resolution (*3DIG*) can only be active when there is at least one digit to the right of a decimal.

3DIG - Set display for 3 digit resolution

4DIG - Set display for 4 digit resolution

*P*dS (Process Display) SUB MENU

STD - Display reads pressure, velocity, or flow values

PCT - Display reads % of full scale value

When the display is reading percent, *PCT* is displayed in the upper right of the display. The percent display is only available in pressure operation.

*D*AMP (Dampening) SUB MENU

Adjust from 1-16

Dampening stabilizes the display from instabilities due to things such as vibration and excessive pressure fluctuations. The dampening setting adjusts the amount of readings that are averaged for each display update. Adjust the dampening value until the display reads a stable value for the application.

*R*dU (Advanced) MAIN MENU

POL - Process output low

ZERO - Zero calibration

POH - Process output high

SPAN - Span calibration

MSP1 - Maintenance set point 1

MSP2 - Maintenance set point 2

POL and *POH* (Process Output Low and High) SUB MENUS

This feature is used in pressure operation only.

Process output low and high are used to scale the 4-20 mA output. Set *POL* to the desired display reading for 4mA output, and set *POH* to the desired display reading for 20 mA output. *POH* must be higher than *POL*. *POL* may be adjusted 2% BELOW minimum scale up to *POH*. *POH* may be adjusted from *POL* to 2% ABOVE maximum scale.

MSP1 and *MSP2* (Maintenance Set Point 1 & 2) SUB MENUS

Adjust for the desired maintenance set points when the unit is placed in the maintenance mode. The deadband is fixed at 2% of full scale. To enter or leave the maintenance mode, press and hold the  for 8 seconds.

ZERO and *SPAN* (Calibration of Zero and Span) SUB MENUS

The lower display reads *CAL* in this mode.

ZERO Calibration

NOTE: For accurate calibration, DO NOT apply any pressure when performing this function.

With the display reading *ZERO*, press the ENTER key. The upper display will blink. Press ENTER again to complete the zeroing of the instrument or press the *MENU* key to cancel.

SPAN Calibration

With the display set to *SPAN*, apply full scale pressure to the unit. Press the ENTER key. The upper display will blink. Press ENTER again to complete the calibration or press the *MENU* key to cancel.

